

---

## Check Valves

---

- **PROTECT EQUIPMENT FROM BACKFLOW DAMAGE IN STEAM AND WATER LINES**
- **RAPID AUTOMATIC CLOSURE IN RESPONSE TO BACK FLOW OR ACTUATOR CONTROLLED CLOSURE TO ALLOW TWO- WAY FLOW**
- **VARIETY OF CONFIGURATIONS AVAILABLE TO MEET CRITICAL APPLICATION REQUIREMENTS**

### Description

Schutte & Koerting Check Valves prevent backflow in steam and water lines to protect valuable equipment from damage.

Used in extraction lines from steam turbines to feedwater heaters, heating systems or process equipment, these valves are engineered for exceptional reliability.

Under normal flow conditions, a counterbalance weight holds the disc in position for free flow of steam or water. However, the slightest back flow will cause the disc to close tightly against the seat, preventing reverse flow through the valve.

Where reverse flow is desired, the valves can be configured to remain open until closed by a cylinder actuator on signal.

S&K check valves are available in a variety of configurations for suitability to your application requirements. In addition, they can be manufactured with soft packing, hardened leak-off bushings, and various materials for critical applications.

Complete physical testing offered by S&K includes hydrostatic and pneumatic testing as well as magnetic particle (magnaflux) and radiographic (x-ray) inspection. All models are ANSI rated.



The basic Type 828 Check Valve protects against back flow of steam or water. The weight linked to the disc provides a delicate counterbalance to the weight of the disc itself. With normal flow in the proper direction the disc swings open to permit full flow. The slightest back flow will close the disc tightly against the seat, preventing reverse flow through the valve.

In applications where a controlled reverse flow is desired, these valves can be arranged to remain open until closed by a cylinder actuator on signal. Typical “hold open” arrangements are described on page 3.

In other applications these valves have been equipped with a spindle to act as both a stop and check valve.

**DESIGN FEATURES**
**Simple on-line maintenance.**

S&K check valves are designed to permit full access to internal components without removal from the pipeline. This can reduce maintenance and inspection costs considerably.

**Reduced distortion.**

Because S&K valves have a vertical seat, welding ends can be as long as needed without interfering with the use of a boring bar during finishing operations. This helps prevent distortion of the seat areas during welding and heat treating. The ends are located at least one pipe diameter away from the body proper in valves up to 4 inches, and up to 8 inches away in larger sizes.

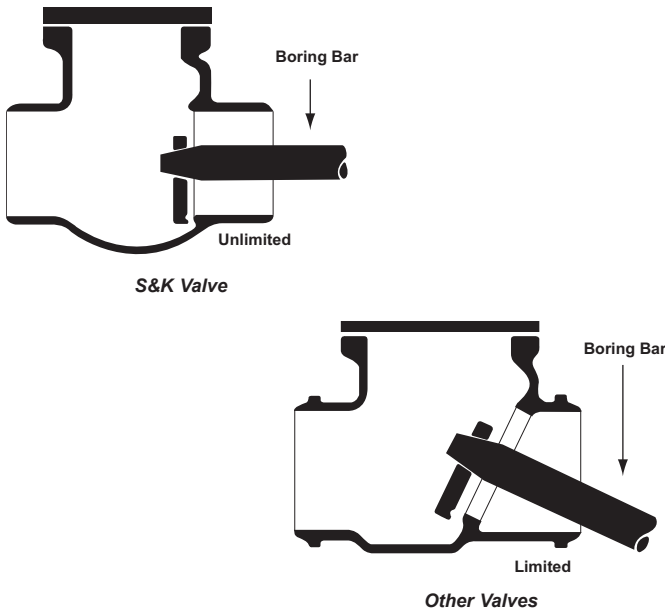
**DESIGN FEATURES**
**Rapid closure in response to backflow.**

The S&K check valve is designed to permit full flow when open only 55° from vertical (below). This disc position makes the valve far more sensitive to backflow and results in faster closing than possible with other designs.

**Low pressure drop.**

The unique full-flow disc position described above, together with the straight-line flow characteristics of its globe-shaped body, produce minimal pressure drop through the valve.

**Minimal valve binding.**

Rockshafts are made of stainless steel with bushings of Monel. Freezing or binding is far less likely to occur than in valves using less corrosion-resistant materials. When intended for service in vacuum lines, rockshafts are provided with water seal lanterns.

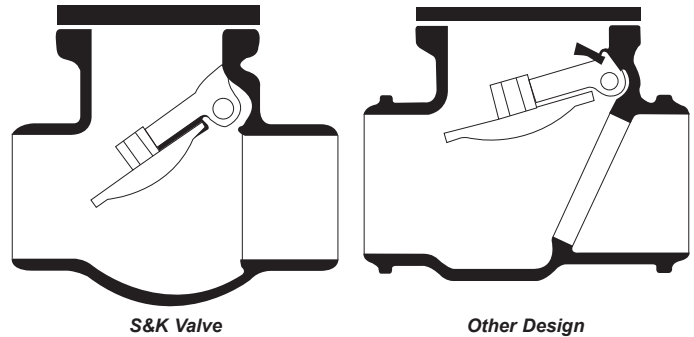
**BASIC CONFIGURATION AND COMPONENTS OF STANDARD VALVE BODY**
**Configuration Options**

Schutte & Koerting offers check valves in a variety of standard configurations to maximize application versatility and meet special service conditions. The configurations described are just the beginning of the tremendous versatility offered by S&K. Many of our customers count on us to apply our custom application engineering to meet the specific requirements of the installation.

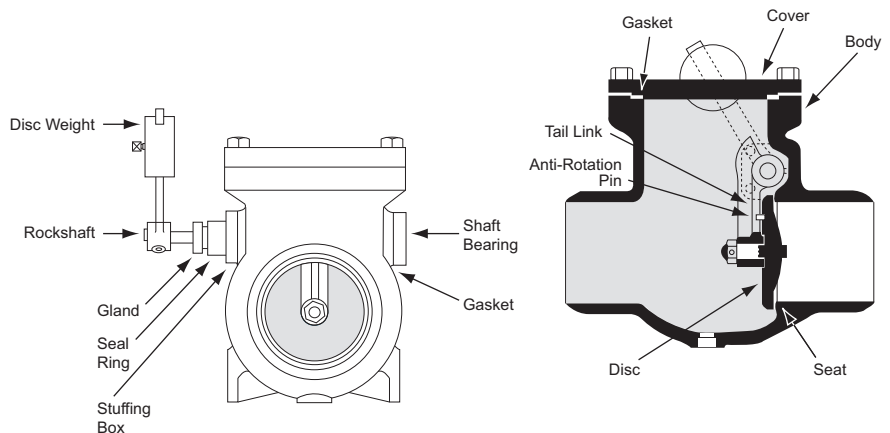

**STANDARD BODY DESIGNS**

**Basic Check Valve**

- For low-pressure (up to 300 lbs. ANSI) applications.
- Designed to reduce packing friction on the shaft.
- Raised face flange with a confined spiral-wound gasket at the cover and rockshaft retainers.

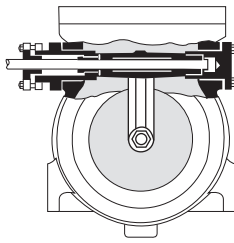

**Through-Sprindle Design**

- For high-pressure (over 300 lb. ANSI) applications.
- “Through sprindle” arrangement balances the higher stem thrusts of these applications.

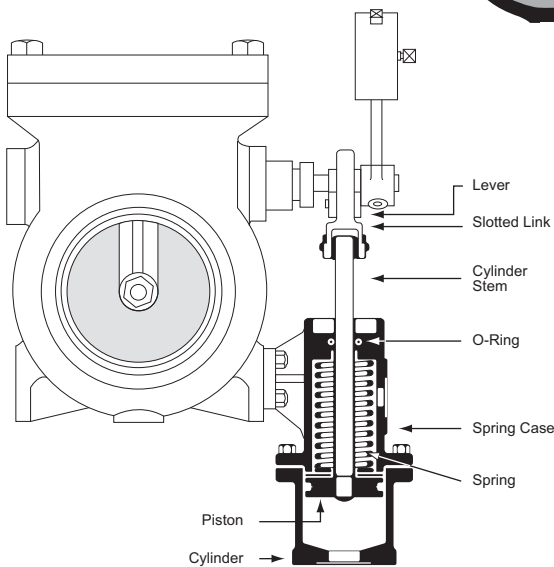
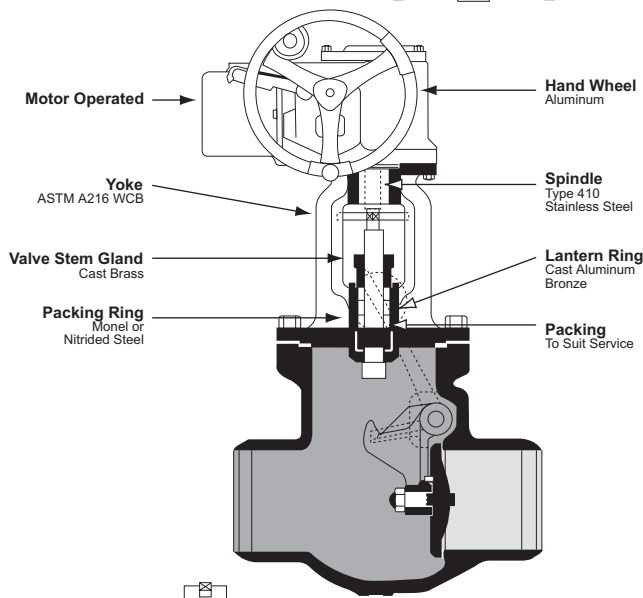
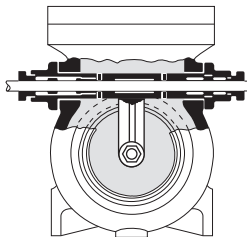

**Controlled Reverse Flow**

- Valve remains open for bi-directional flow until closed by an actuator.
- In low-pressure (under 300 lbs. ANSI) applications (below left), the disc is held in place until closed by the actuator, which can be direct-connected.
- In high-pressure applications (above right), the keyway is enlarged to allow the disc to swing freely until closed by the actuator.

**Cylinder Closure Assist**

- Oil- or air-operated cylinder provides additional safety measure to ensure positive closure in critical applications.
- Disc swings freely until pressure fails.
- Cylinder supplies initial impact to the rockshaft and disc to overcome freezing in the open position.
- Can be mounted on either side of the valve.

**Pilot and Relay Valves**

- For use with the oil- or air-operated cylinders.
- Can be used for hand-operated pilot and relay services.
- Available in both straight-through and three-way bodies in sizes from 1/4” to 3” with threaded or flanged connections.

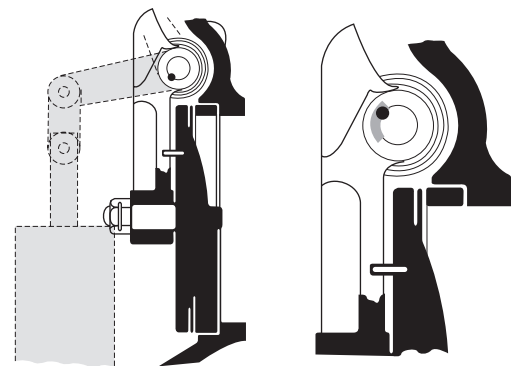

**SPECIFICATIONS**

Size No.	Dimensions <sup>1</sup>						Weld. Ends <sup>2</sup>	Flanges ANSI Std.				Approx. Wgt. Lbs.	K Factor <sup>3</sup>
	A	B	C	D	E	F		H 150#	H 300#	H 400#	H 600#		
3	10 1/8	4 1/8	15 1/8	3 3/4	7 3/4	-	14	11	12	13	13 1/2	190	0.792
4	10 5/8	4 5/8	14 1/2	4 1/4	8 1/2	-	16	13	14	16	17	230	0.759
5	15 3/8	6	19 1/8	5	10 1/4	11 1/2	17 1/2	15	16	18	20	340	0.731
6	15 3/8	6	18 1/2	5 3/4	11 1/8	16 5/8	19	16	17	19 1/2	22	500	0.710
8	16 5/8	7 1/4	17 3/8	7 3/8	13 3/4	17 3/4	21 1/2	18	20	23 1/2	26	650	0.675
10	18 3/8	9	16 1/2	9 1/4	14	20 1/8	24 1/2	22	23	26 1/2	31	780	0.648
12	19 7/8	10 1/4	15 1/4	10 1/4	17	21 1/2	28	24	26	30	33	950	0.627
14	20 13/16	11	23 9/16	11 5/8	18 13/16	25 3/8	32 1/2	28	30	31	32	1800	0.608
16	24 1/4	14 1/4	22	12 3/4	20 1/4	32	36	30	33	38	39	1900	0.592
18	24 1/4	14 1/4	21 1/4	13 11/16	22 1/8	32 3/4	40	34 1/2	36	37	39	2000	0.579
20	27	17	19 1/2	16 1/8	24 1/2	34 1/2	44	36	39	43 1/2	47	3600	0.565
24	31 11/16	21 3/4	17 1/4	18	27 7/8	36 3/4	50	44	45	46	48	4500	0.543
30	36 1/4	26 1/4	17 1/4	22	34 5/8	41	61	52	55	57	59	7600	0.518

1. All dimensions are in inches.

2. For pipe schedules 20, 40, and 60. For pipe schedules 80, 100, and 120, contact the company.

3. For determining pressure drop. Refer to engineering data for instructions on how to calculate pressure drop.

S&K check valves conform to ANSI ratings, B16.5.

