Throttle / Trip Valves

- FLOW CONTROL AND AUTOMATIC SHUT-OFF IN A SINGLE VALVE ASSEMBLY
- COMPACT, RUGGED DESIGN WITH MOTORIZED OR MANUAL OPERATION
- VARIETY OF CONFIGURATION OPTIONS FOR EXCEPTIONAL OPERATION AND INSTALLATION VERSATILITY

Description

Schutte & Koerting throttle/trip valves provide effective flow control and emergency shut-off operation in a single, highly reliable valve assembly.

As throttle valves, they are used to regulate flow of steam and gas in large, high-pressure pipe lines, such as the main steam line serving a large, high-pressure turbine or a turboexpander gas supply line.

As trip valves, they add a measure of safety critical to these applications, without the expense of a separate trip valve. When tripped either manually or automatically, the valves rapidly shut down flow to protect valuable equipment.

Throttle Valve Function: The valve can be opened or closed to any desired flow by means of a motorized operator or manual handwheel.

An integral pilot valve opens first as the spindle is rotated, releasing steam in the balancing chamber to the downstream side. This reduces chamber pressure to well below inlet line pressure to ease subsequent opening of the main disc.



Trip Valve Function: The trip valve mechanism is activated by means of an air cylinder, oil cylinder, or solenoid. A manual lever can also be provided.

When tripped, the latch lever is automatically disengaged from the latch hook. Working with the pressure of the internal steam or gas, a powerful compression spring in the yoke forces the entire spindle mechanism against the seat. A manual lever can be provided for operator override.

Design Features

Reduce load on disc for smooth opening. S&K throttle/trip valves feature an internal pilot valve arrangement to relieve pressure on the main disc as the valve is opened.

Reduced distortion. The seal-welded seat ring is shrink-fit to the body and includes an expansion groove, to prevent distortion of the seating face.

Durable materials improve performance and reduce wear. Wear-resistant materials - including hardened, nitrided stems and bushings - are used at all critical points to ensure long service life and eliminate soft packing. Flexitallic-type gaskets provide positive sealing at all cover joints.

Simple on-line maintenance. S&K throttle/trip valves are designed for simple on-line adjustment of the yoke and latching assembly.

Low-friction operation. Optional ball bearing, threaded spindle and latching mechanisms are available to provide mechanical assist for reliable low-friction operation.

Compact configuration. Venturi seats can be provided in high-pressure applications, reducing space requirements and allowing use of smaller operators.

Choice of connections. Valves may be specified with welded ends or ANSI flange connections for direct connection to steam turbines.

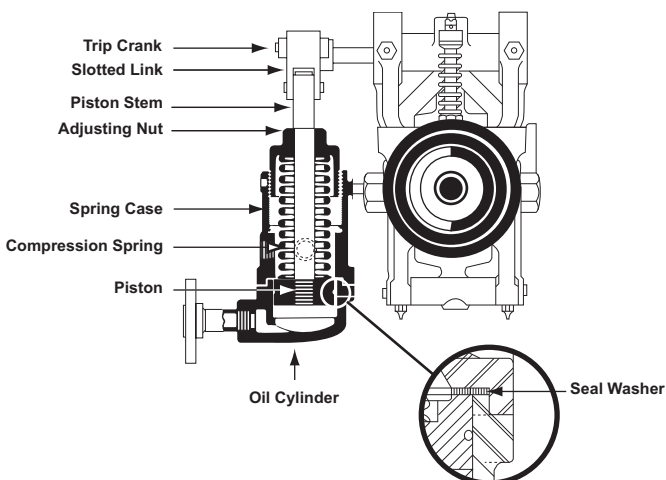

OIL TRIP CYLINDER

- Provides automatic shutdown of valve during pressure drop to protect the turbine from damage.
- Mounted on the valve yoke and connected to the turbine control oil line.

Configuration Options

Schutte & Koerting offers three basic body designs and a variety of configuration options to help you obtain the ideal throttle/trip valve according to your service and installation requirements. In addition to the configurations described below, our highly experienced engineers can work with you to design a valve to meet virtually any application need.

Standard Body Designs

Through-Hole Spindle Design

- Used with 6" dia. and larger valves, or any valve in high-pressure (over 600 lb) service.
- Provides equal distribution of spindle forces.

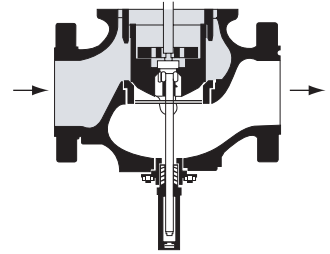

Top-Guided Spindle Design

- Used with 3" valves where line pressure does not exceed 600 lbs.
- Spindle terminates at the main disc.

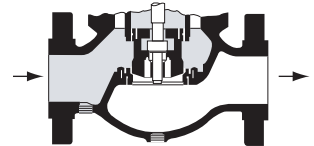

Top & Bottom-Guided Spindle Design

- Used with 4" and 5" valves where line pressure does not exceed 600 lbs.
- Pilot valve stem guide provides rigidity and ensures proper alignment of disc to seat.

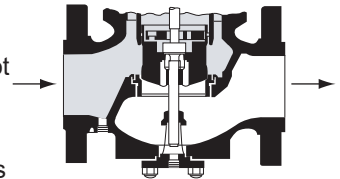

Corner Body Design

- Available configuration for any of the standard body styles above.
- Gas/Steam outlet can be placed on either the right or left side, as required by the installation.

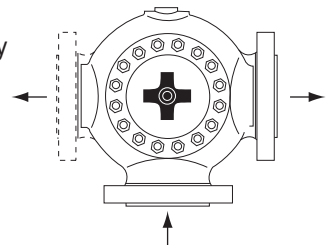

- Turbine control oil holds compression spring in place to keep valve open during normal operation.
- When oil pressure drops below limit, the spring immediately overpowers the oil and disengages the latch mechanism allowing the large yoke spring to close the valve.

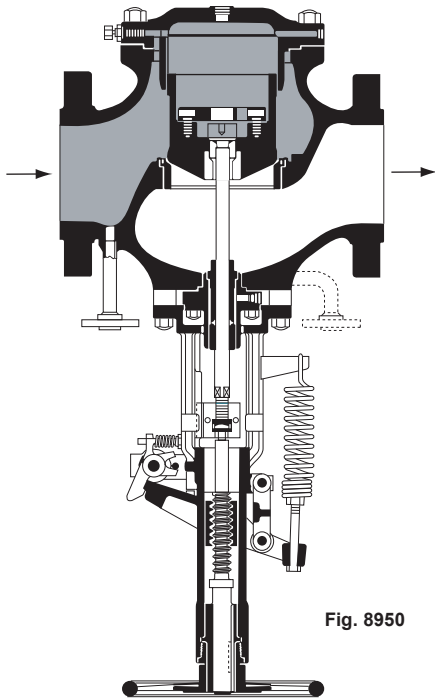

Fig. 8950

- OVERHEAD INSTALLATION**
- Used where valves are actuated from below pipeline.
 - Inverted valve handwheel, pilot valve and main valve disc./seat.
 - Extension spring used on the tripping mechanism instead of compression spring.
 - Motor operators and tripping devices available.

- MOTORIZED OPERATION**
- Equipped with motor operator and manual override.
 - "Explosion-proof"* motor used in connection with a gas turbo-expander.
 - Can be incorporated into any S&K throttle/trip valve design.
- * N.E.C. Class 1, Groups A, B, C or D

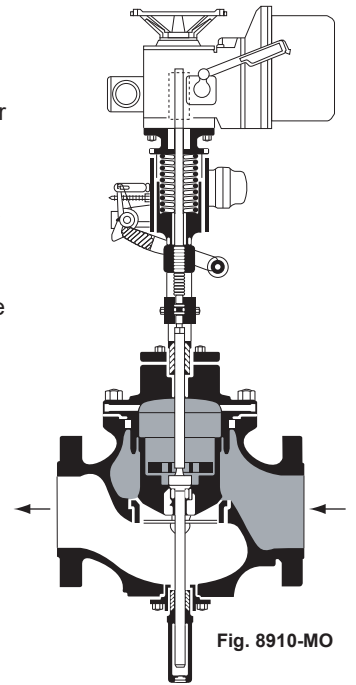

Fig. 8910-MO

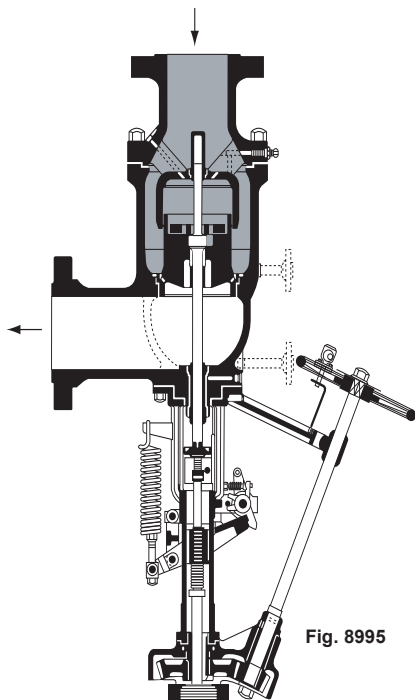
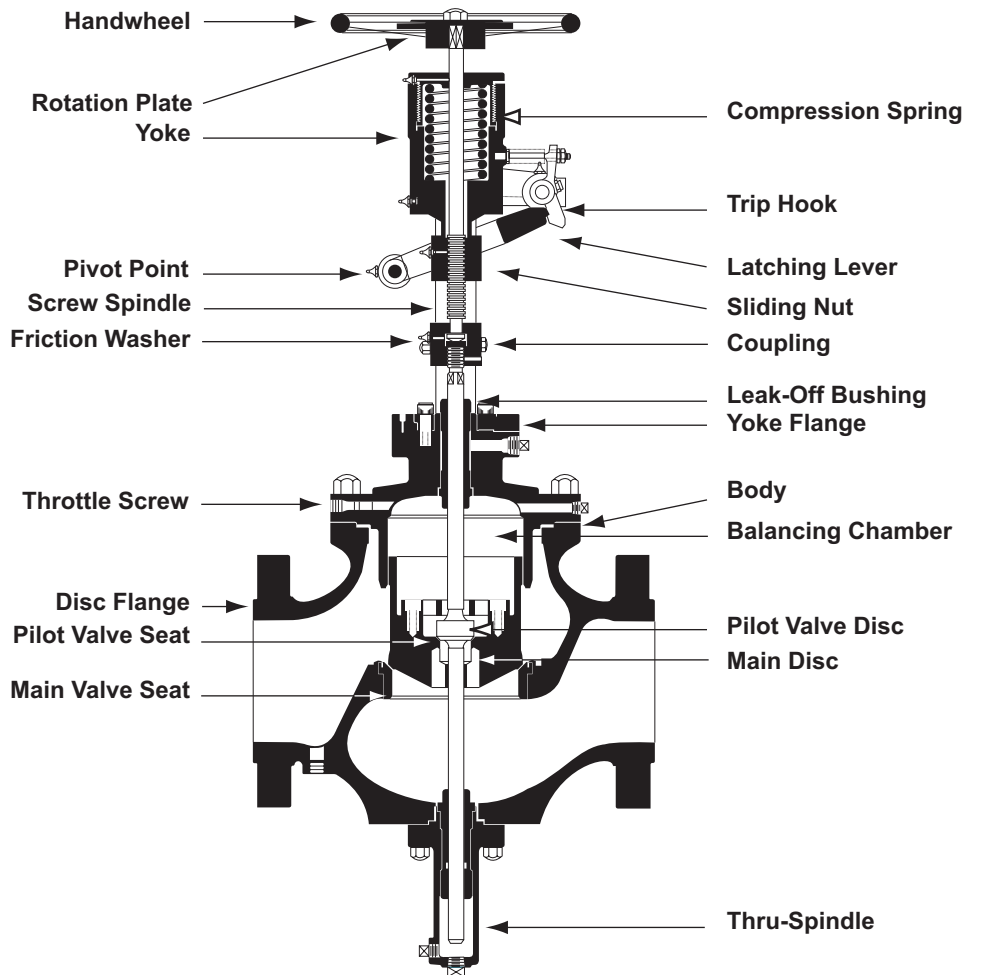

Fig. 8995

TOP INLET, INCLINED HANDWHEEL ARRANGEMENT

- Inverted valve orientation with inlet at the top.
- Upright, inclined hand-wheel operates the spindle through a bevel gear and pinion arrangement.
- Can be equipped with motor operators and tripping devices.



SPECIFICATIONS - FIG. 8910

Size (Pipe Conn. In In.)	Dimensions, In Inches ¹						K Factor ²
	A	B	C	D	E	F	
FOR PRESSURES TO 300 LBS. WSP (WORKING STEAM PRESSURE)							
3	13	6 1/2	-	30 9/16	12	-	4.6
4	14 3/4	7 3/8	-	31 13/16	12	5	4.3
6	18 1/2	9 1/4	16 1/2	43 1/8	16	7 1/8	4.0
8	24	12	18 5/8	46 1/8	16	9 1/4	3.7
10	30 1/4	15 1/8	19 5/8	48 1/2	16	10 1/4	3.6
12	34	17	22 3/8	55 5/8	20	13 3/8	3.5
FOR PRESSURES TO 400 LBS. WSP							
3	13 3/4	6 7/8	-	30 9/16	12	-	4.6
4	15 1/2	7 3/4	-	31 13/16	12	5	4.3
6	19 1/2	9 3/4	16 1/2	43 1/8	16	7 1/8	4.0
8	25	12 1/2	18 5/8	46 1/8	16	9 1/4	3.7
10	31 1/4	15 5/8	19 5/8	48 1/2	16	10 1/4	3.6
12	35	17 1/2	22 3/8	55 5/8	20	13 3/8	3.5
FOR PRESSURES TO 600 LBS. WSP							
3	13 3/4	6 7/8	-	30 9/16	12	-	4.6
4	15 3/4	7 7/8	-	31 13/16	12	5	4.3
6	20	10	16 1/2	43 1/8	16	7 1/8	4.0
8	25 3/4	12 7/8	18 5/8	46 1/8	16	9 1/4	3.7
10	32	16	19 5/8	48 1/2	16	10 1/4	3.6
12	35 3/4	17 7/8	25 1/4	55 5/8	30	13 3/8	3.5
FOR PRESSURES TO 900 LBS. WSP							
3	15	7 1/2	11 11/16	30 9/16	12	4 1/2	4.6
4	17	8 1/2	12 5/8	31 13/16	12	5 7/16	4.3
6	22	11	16 3/4	43 1/8	16	7 3/8	4.0
8	28	14	18 3/4	46 1/8	16	9 3/8	3.7
10	35	17 1/2	19 5/8	48 1/2	16	10 1/4	3.6
12	39 1/2	19 3/4	25 1/4	59 11/16	24	13 3/8	3.5

- Above dimensions are approximate. Certified outline dimension prints will be submitted for approval upon receipt of order.
- Request technical data for calculating pressure drop using "K" factors.

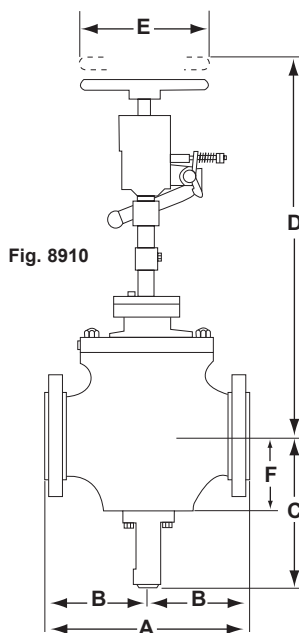

SPECIFICATIONS - FIG. 8950

Size (Pipe Conn. In In.)	Dimensions, In Inches ¹					K Factor ²
	A	B	C	D	E	
FOR PRESSURES TO 300 LBS. WSP (WORKING STEAM PRESSURE)						
3	13	6 1/2	6 1/4	31	12	4.6
4	14 3/4	7 3/8	7 1/4	33 7/16	12	4.3
5	16 3/4	8 3/4	8 9/16	34 15/16	12	4.2
6	18 1/2	9 1/4	10 5/16	41 3/8	16	4.0
8	24	12	13 7/16	44	16	3.7
10	30 1/4	15 1/8	16 1/8	45 3/4	16	3.6
FOR PRESSURES TO 400 LBS. WSP						
3	13 3/4	6 7/8	6 1/4	31	12	4.6
4	15 1/2	7 3/4	7 1/4	33 7/16	12	4.3
5	17 1/2	8 3/4	8 9/16	34 15/16	12	4.2
6	19 1/2	9 3/4	10 5/16	41 3/8	16	4.0
8	25	12 1/2	13 7/16	44	16	3.7
10	31 1/4	15 5/8	16 1/8	45 1/2	16	3.6
FOR PRESSURES TO 600 LBS. WSP						
3	13 3/4	6 7/8	6 1/4	31	12	4.6
4	15 3/4	7 7/8	7 1/4	33 7/16	12	4.3
5	18	9	8 9/16	34 15/16	12	4.2
6	20	10	10 5/16	41 3/8	16	4.0
8	25 3/4	12 7/8	13 7/16	44	16	3.7
10	32	16	16 1/8	45 1/2	16	3.6
FOR PRESSURES TO 900 LBS. WSP						
3	15	7 1/2	6 1/2	31 3/16	12	4.6
4	17	8 1/2	7 5/8	33 13/16	12	4.3
5	20	10	8 9/16	34 15/16	12	4.2
6	22	11	10 3/4	41 5/8	16	4.0
8	28	14	13 3/4	44 1/8	16	3.7
10	34	17	16 5/8	45 3/4	16	3.6

