

## Water Jet Exhausters and Compressors

- **Single and Multi-Nozzle Types**
- **For vacuum pumping and mixing operations**

Schutte & Koerting water jet exhausters are simple, efficient and versatile devices for vacuum pumping or mixing liquids and gases. Using pressurized water as the only motive force, these units are ideal for handling mixtures of condensable and non-condensable gases and they operate at ground level. Typical applications include: pump priming, evacuating closed vessels, pumping and mixing of liquids and gases.

S&K manufactures single and multi-nozzle water jet exhausters. Each type is described on the following pages. Bulletins 4E and 5E-H describe exhausters that use steam or compressed air as the motive force.

### DESIGN FEATURES

**Low Cost** - The inherent simplicity of S&K exhausters makes them low in initial cost. Operation and maintenance costs are also minimal since they have no moving parts and are subject to little wear.

**Easy Installation** - Only three connections are required, and stop valves in the water and suction lines are the only auxiliary devices required. The discharge end must be sealed to prevent air back flow.

**Versatile and Reliable** - Even under severe service conditions these exhausters will operate reliably. They can be used where other pumping devices would not be practical and are ideal for intermittent service.

**Wide Selection** - S&K offers a wide variety of water jet exhausters. To select an exhauster for your specific application refer to Technical Supplement 4P for sizing data.



**Single-Nozzle  
High Capacity  
Water Jet Exhauster**

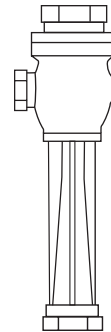

**Multi-Nozzle  
High Capacity  
Water Jet Exhauster**

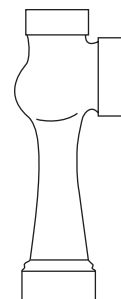

**Single-Nozzle  
General Purpose  
Water Jet Exhauster**

<u>Index</u>	
Description	Page
Fig. 484 Single Nozzle High Capacity Water Jet Exhauster	2
Fig. 488 & Fig. 489 Multi-Nozzle, High Capacity Water Jet Exhauster	3
Fig. 464 Single-Nozzle, General Purpose Water Jet Exhauster	4
Fig. 265 & Fig. 485 Single Nozzle Water Jet Exhauster	4

**FIG. 484 SINGLE-NOZZLE, HIGH CAPACITY WATER JET EXHAUSTER**

Very high capacities can be obtained with S&K Single-Nozzle Exhausters. Standard materials of construction include:

- (a) cast iron with bronze nozzle
- (b) bronze with bronze nozzle
- (c) stainless steel with stainless steel nozzle

Other materials can be supplied on special order, including Monel, Evedur, Phenolic Fiberglass Reinforced Plastic (FRP), lead, fiberglass and Teflon.

For complete performance characteristics, see Technical Supplement 4P.



Fig. 5. Fig. 484 Single-Nozzle Water Jet Exhauster

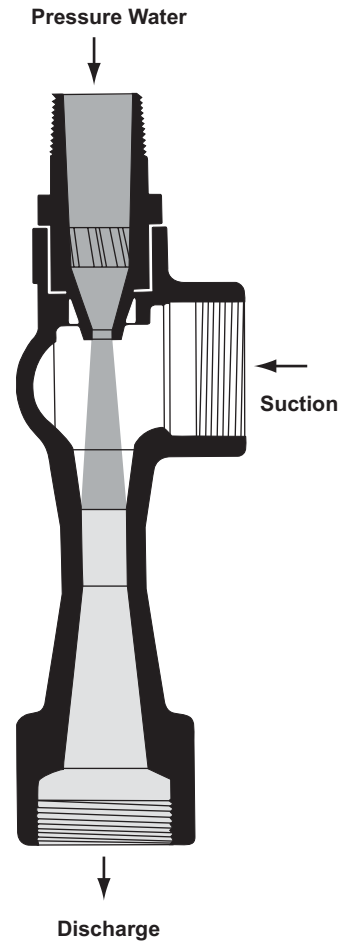
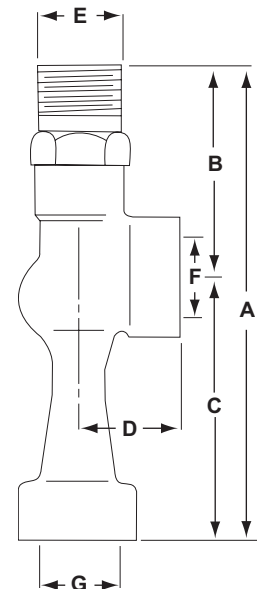

Fig. 6. Sectional Drawing, Fig. 484 Single-Nozzle Exhauster

**Table 2. Sizes, Dimensions, and Weights of Fig. 484 Water Jet Exhausters**

Size (Inches)	Dimensions (Inches)							Approx. Weight (Lbs.)
	A	B	C	D	E	F	G	
1/2	4 15/16	2 3/8	2 9/16	1 1/8	1/2	1/2	1/2	1
3/4	6	2 5/8	3 3/8	1 1/4	3/4	3/4	3/4	1 1/2
1	6 15/16	2 3/4	4 3/16	1 5/8	1	1	1	2 1/2
1 1/2	10 1/16	3 9/16	6 1/2	2	1 1/2	1 1/2	1 1/2	3 1/2
2	12 3/8	4 3/4	7 5/8	2 1/4	2	2	2	7
2 1/2	15 7/16	6 3/16	9 1/4	3 1/8	2 1/2	2 1/2	2 1/2	13
3	17 7/8	6 5/8	11 1/4	3 1/2	3	3	3	25



**FIG. 488 AND FIG. 489 MULTI-NOZZLE, HIGH CAPACITY WATER JET EXHAUSTERS**

- Peak capacity units
- Threaded and Flanged connections

Multi-Nozzle Exhausters are manufactured to provide high air or vapor handling capacities at low operating pressures. They are available in 13 standard sizes - the smallest two with threaded connections (Fig. 488) and the others in flanged connection (Fig. 489).

Multi-nozzle exhausters can also be made of many materials such as cast iron, bronze, stainless steel and Phenolic Fiberglass Reinforced Plastic (FRP). They can also be lined with abrasion-and corrosion-resistant materials such as rubber, carbon and Penton.

For complete performance characteristics, see Technical Supplement 4P.



Fig. 7. Type 488 Multi-Nozzle Exhauster with Threaded Connections.



Fig. 8. Fig. 489 Multi-Nozzle Exhauster with Flanged Connections.

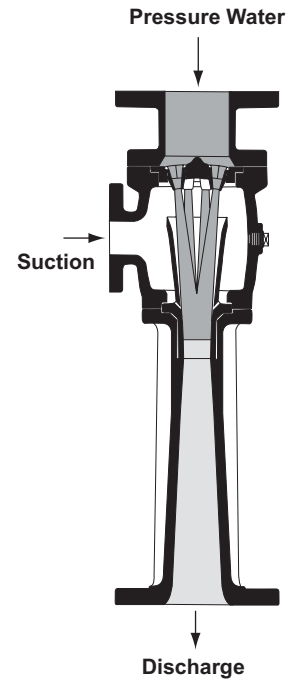

**Table 3. Sizes and Dimensions of Water Jet Exhausters - Fig. 488 and Fig. 489**

Size No.	Connections (Inches)			Dimensions (Inches)				Weight (Lbs.)
	Pressure	Suction	Discharge	A	B	C	D	
1	1 1/2	1	1 1/2	5 3/16	13 1/8	3 3/8	2 3/4	23
2	2 1/2	1 1/4	2 1/2	5 1/4	16 3/8	3 3/4	3 1/16	46
3	3	1 1/2	3	6 13/16	17	4	3 1/4	65
4	4	2 1/2	4	8 3/16	20 7/8	6 1/4	4 1/2	125
5	4	2 1/2	4	8 1/8	20 7/8	6 1/4	4 1/2	150
6	5	3	5	10	23 1/2	6 1/2	5 1/16	215
7	5	3	5	10	23 1/2	6 1/2	5 1/16	230
8	6	4	6	10 1/8	32	8	6 1/8	320
10	8	5	8	12 13/16	37 3/16	9 3/4	7 3/4	430
12	10	6	10	15	40	11	9	-
14	12	8	12	17	45	12 1/2	10	-
16	14	8	14	20	52	16	13	-
18	14	10	14	21	60	16	13	-

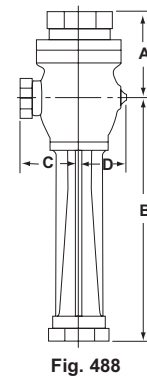

Fig. 488

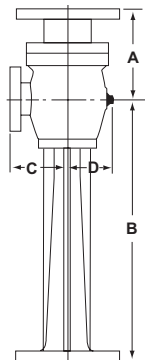

Fig. 489

**FIG. 464 GENERAL PURPOSE WATER JET EXHAUSTERS**

For laboratory or other general purposes, the S&K Fig. 464 Exhauster is available in such materials as cast iron, bronze, stainless steel, Kynar, polypropylene, and PVC. It has also been supplied in titanium, Monel, Hastelloy and Teflon. The Fig. 464, a single-nozzle low cost exhauster, is meant to supplement the Fig. 484 exhauster and be used when efficiency is not of prime importance.

For complete performance characteristics, see Technical Supplement 4P.



Fig. 9. Fig. 464 Single-Nozzle Water Jet Exhauster

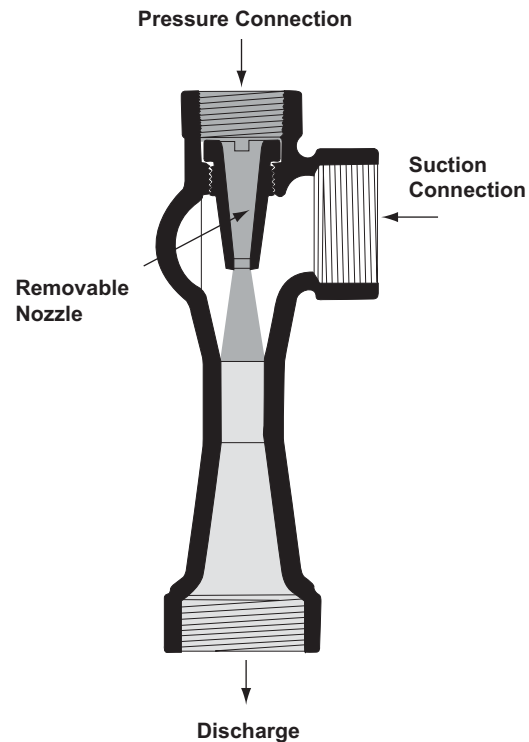
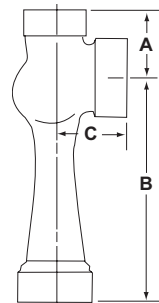

Fig. 10. Sectional Drawing Fig. 464 Single-Nozzle Water Jet Exhauster

**Table 4. Sizes and Dimensions - Fig. 464 Water Jet Exhausters**

Size (Inches)	Connections (Inches)		Weight (Lbs.)	Dimensions (Inches)		
	Suction Discharge	Pressure		A	B	C
1/2	1/2	3/8	3/4	1 1/16	2 9/16	1 1/8
3/4	3/4	1/2	1 1/4	1 3/8	3 3/8	1 1/4
1	1	3/4	2	1 1/2	4 3/16	1 5/8
1 1/2	1 1/2	1	4	2	6 1/2	2
2	2	1 1/4	6	2 1/4	7 5/8	2 1/4
2 1/2	2 1/2	1 1/2	11	2 11/16	9 1/4	3 1/8
3	3	2	20	3 1/8	11 1/4	3 1/2



**FIG. 265 & FIG. 485 WATER JET EXHAUSTERS**

Fig. 265 & Fig. 485 Water Jet Exhausters are similar in design to the Fig. 464 Water Jet Exhauster and is made for liquid pumping and mixing operations and for handling some solids where requirements do not necessitate capacities greater than those obtained with sizes up to and including 3”.

The Fig. 265 & Fig. 485 Water Jet Exhausters provide higher discharge pressures and higher suction flow capacities than other standard exhausters.

In operation, pressure liquid enters the exhauster through the pressure nozzle and produces a high velocity jet. This jet action creates a vacuum in the line which causes the suction air or gas to flow up into the body of the exhauster where it is entrained by the pressure liquid. Both liquid and air are thoroughly mixed in the throat of the exhauster and are discharged against back pressure. The streamlined body with no pockets permits the pressure liquid to move straight through the exhauster and reduces the possibility of solids in the suction material from collecting and clogging. In addition, pressure drop in the suction chamber is held to a minimum.

Accompanying Bulletin 4P Supplement Performance Data provides performance information.

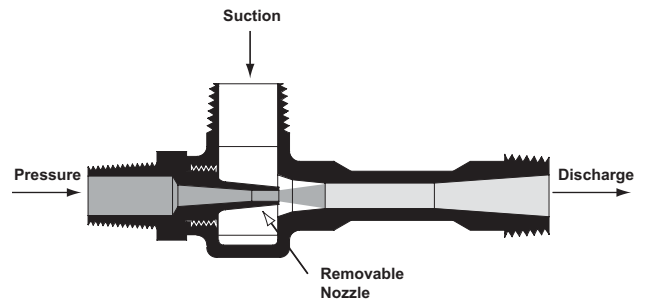

**Fig 11. Fig. 265 & Fig. 485 Water Jet Exhausters**  
Exhausters of this type have streamlined investment cast bodies with threaded NPT male pipe connections. They are made in sizes ranging from 3/4” to 3” and are stocked in these sizes in Fig. 316 stainless steel. Other materials are available on order.



**Fig. 12. Fig. 265 & Fig. 485 Water Jet Exhausters**

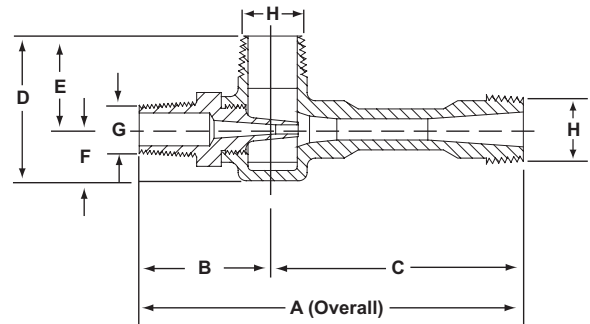

**Table 465. Sizes and Dimensions, Fig. 265 & Fig. 485 Liquid Jet Exhausters**

Size (In Inches)	Wgt.	Dimensions						Connections	
		A	B	C	D	E	F	G	H
3/4	1	5 7/8	2	3 7/8	2 1/4	1 1/2	3/4	3/8	3/4
1	2	7 1/8	2 1/4	4 7/8	2 3/4	1 3/4	1	1/2	1
1 1/2	4	11	2 3/4	8 1/4	3 21/32	2 1/2	1 5/16	1	1 1/2
2	8	14 3/8	3 1/8	11 1/4	5	2 7/8	2 1/8	1 1/4	2
3	30	23 7/8	4	19 7/8	7	4	3	2	3

**Typical Applications**

Water Jet Exhausters have been employed in many different industries for different purposes. Generally, their application can be divided into three main categories: (1)

priming pumps, (2) evacuating closed vessels, and (3) vacuum pumping or mixing operations. Each of these basic applications is illustrated below.

**Pump Priming**

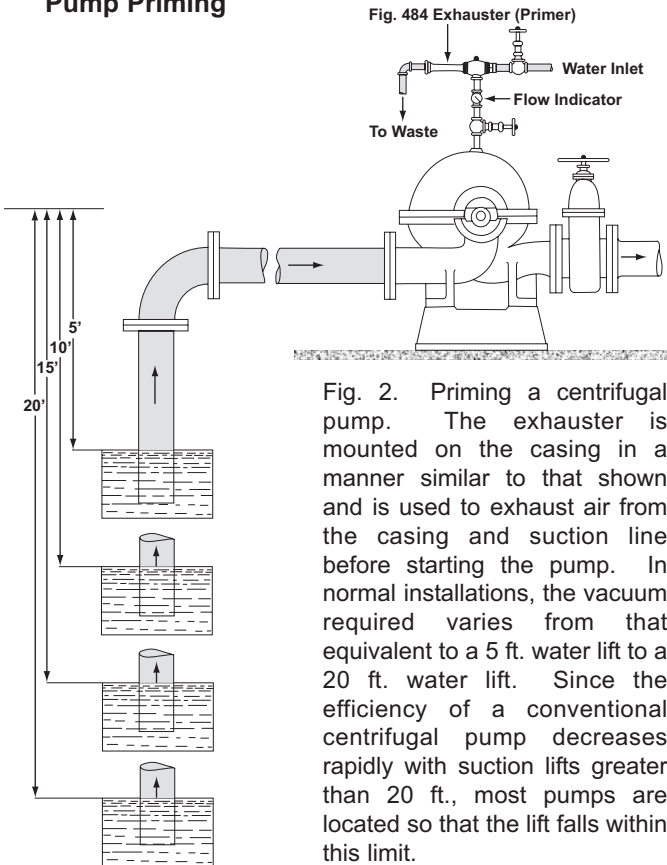

Fig. 2. Priming a centrifugal pump. The exhauster is mounted on the casing in a manner similar to that shown and is used to exhaust air from the casing and suction line before starting the pump. In normal installations, the vacuum required varies from that equivalent to a 5 ft. water lift to a 20 ft. water lift. Since the efficiency of a conventional centrifugal pump decreases rapidly with suction lifts greater than 20 ft., most pumps are located so that the lift falls within this limit.

**Vacuum Pumping**

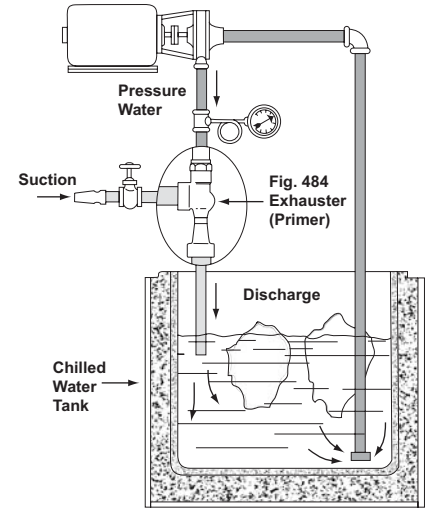

Fig. 3. Simple laboratory arrangement for obtaining low suction pressures with a water jet exhauster using chilled water at about 35°F. This system provides suction pressures approaching 5mm Hg absolute. Unlike other types of equipment, water jet exhausters are compact and low in cost and require no lubrication or oil seals which affect operation under certain conditions.

**Evacuating A Closed Vessel**

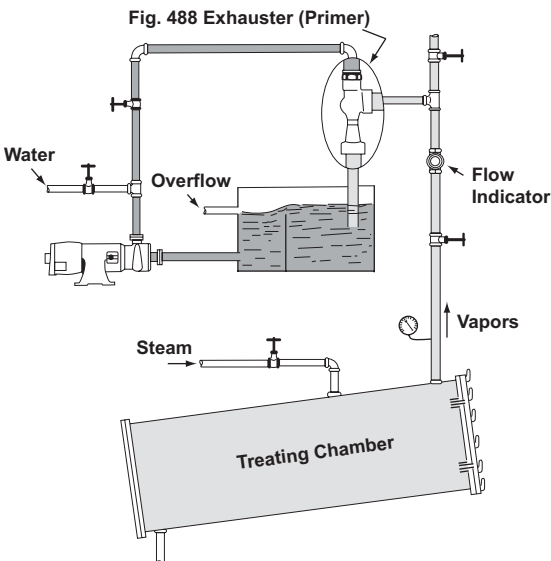

Fig. 4. Typical system for evacuating a closed tank. Steam is employed to flush air from the tank, and steam remaining in treating chamber is condensed by the exhauster. This technique reduces evacuation time. Table 1 gives the time in minutes needed to empty tanks of various capacities using different size exhausters. This method is recommended for tanks having a capacity of more than 120 gallons. Details on this and similar applications are available on request.

**Table 1. Timetable For Evacuating Tank With Fig. 488 Water Jet Exhauster**

Tank Capacity in Gallons	Water Pressure PSIG	To 25" Hg. Vac.		To 26" Hg. Vac.		To 27" Hg. Vac.	
		Time Minutes	Size No.	Time Minutes	Size No.	Time Minutes	Size No.
100	15	3.30	1	3.50	1	4.00	1
500	15	8.25	2	8.75	2	5.00	3
1000	15	5.50	4	5.85	4	6.70	4
2000	15	6.60	5	7.00	5	8.00	5

Note: Time includes 2 minutes preliminary steam flushing. Exhausters in Table are recommended sizes.

## How Water Jet Exhausters Operate

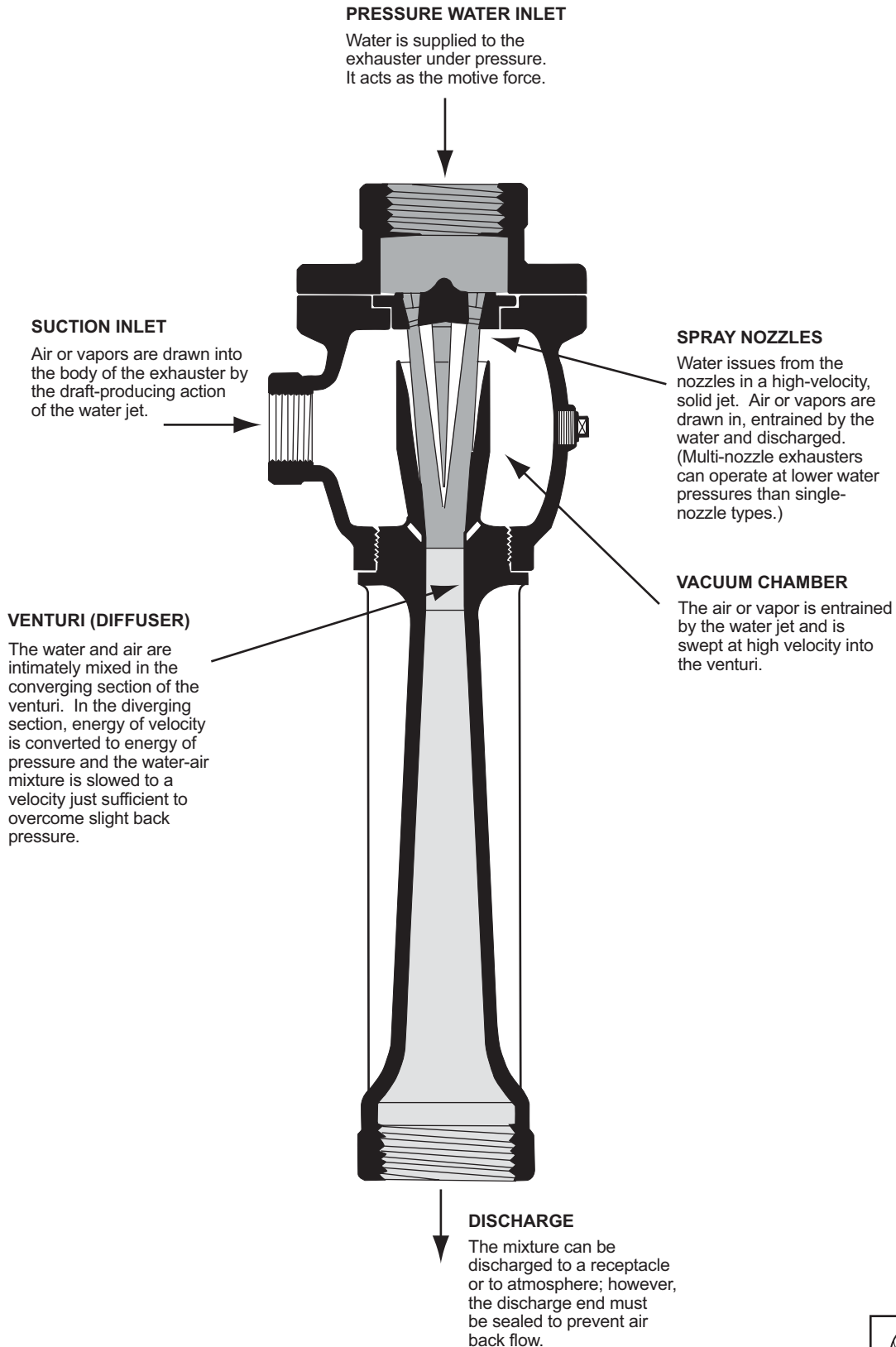

121906

