

Jet Compressors

- **Circulate Steam**
- **Boost Low-Pressure Steam**
- **Compress and Mix Gases in Desired Proportion**

S&K Jet Compressors are used in the process, paper, petroleum, power, gas, and other industries to circulate steam, boost low-pressure steam, and to mix, transfer, and compress gases.

A jet compressor is a type of ejector which utilizes a jet of high-pressure gas as an operating medium to entrain a low-pressure gas, mix the two, and discharge at an intermediate pressure. Gases can be steam, air, propane, or others. When both motive and suction gases are steam, the compressor is generally referred to as a "thermocompressor".

CONSTRUCTION AND OPERATION

They consist of three basic parts, namely: a nozzle, a body, and a diffuser. Fig. 1 identifies these parts and illustrates design and operation.

Jet compressors can be supplied in materials to meet service conditions. Standard materials and components are noted in each section.

Design of the nozzle follows basic thermodynamic laws. Design of the diffuser, however, is still partially empirical. For this reason, S&K's long experience in designing, manufacturing, and testing jet compressors can be very helpful.

The motive gas, under pressure, enters the compressor and flows through the nozzle. The nozzle converts the high-pressure gas into a high velocity jet stream which creates a suction and causes entrainment of the low-pressure gas. The motive and suction gases are mixed in the body. The diffuser then converts the velocity head of the gas mixture to static head so that proper discharge pressure can be obtained.

When required, a steam jacket can be applied on the nozzle and diffuser of the compressor since, in some applications, freezing can occur. A typical example would be a case where natural gas is supplied to the nozzle at 60°F and due to expansion is reduced in temperature to below 0°F at the outlet of the compressor nozzle.

ADVANTAGES

Compared with other types of compressing equipment, jet compressors offer definite advantages. Some of these are as follows:

Jet compressors are simple in construction, have no rapidly rotating parts to break, get out of order, adjust, or replace.

Jet compressors can be made from practically any machinable material - cast iron, bronze, special stainless steels, etc.

Since they require little attention, they can be installed in remote locations.

These compressors can be used in potentially explosive atmospheres without additional safeguards because they have no electrical components.

The jet compressor not only performs the primary function of compressing and mixing gases but, in addition, it takes the place of a reducing valve and salvages much of the energy lost in the reduction of operating-medium pressure.

Compared with other types of equipment, jet compressors are very low in original cost and in upkeep.

Description	Page
Construction & Operation	1
Advantages	1
Types & Sizes	2
Type 420 Jet Compressors	3
Type 425 Jet Compressors	4
Type 427 Jet Compressors	4
Type 426 Jet Compressors	5
Type 439 Jet Compressors	5
Applications	6 - 8

TYPES AND SIZES

Types and sizes of S&K Jet Compressors are listed in the following pages. Types include the following: fixed-nozzle type compressors; compressors with manually-controlled spindle; compressors with automatically-controlled spindle.

Fixed-nozzle type jet compressors are suitable for applications as noted on page 3 where conditions are such that no controls whatever are required, or where use of several compressors in parallel will permit an adequate degree of control.

Normally, some form of flow regulation is required.

In a Jet Compressor, regulation is accomplished by means of a spindle. Unlike a control valve where energy is lost, a spindle reduces the flow without reducing the available energy per pound of gas. This enables the compressor to utilize the maximum energy available at all ranges of flow and extends the capacity variation of a single unit.

Fixed-nozzle compressors are used where the compressor will be operated at a steady load.

Compressors with manually-operated spindles are designed for use where loads will remain steady but where changes in operating conditions may occur or where operating conditions are not sufficiently well known and some flexibility in nozzle orifice size is desirable.

Compressors with automatically-controlled spindles are used where pressure, suction, or discharge conditions vary and it is necessary to control discharge pressure or flow.

PERFORMANCE

Performance data on Jet Compressors is available. Request "Performance Data Supplement to Bulletin 4F." Additional technical data can be obtained by requesting copies of "The Jet Compressor as Applied to the Gas Industry" and "The Performance of Thermocompressors as Related to Paper Machine Dryer Drainage Systems", technical papers on the subject.

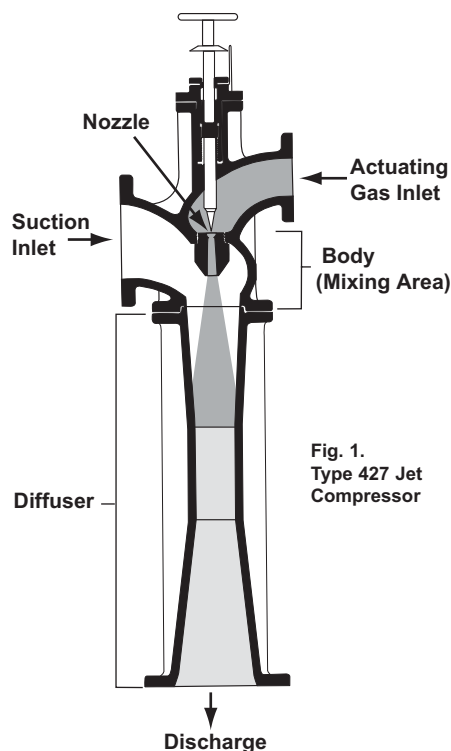

Fig. 1.
Type 427 Jet
Compressor

TYPE 420 JET COMPRESSORS

The Type 420 Compressor has no regulating spindle. The pressure connection is threaded, the suction and discharge connections are flanged, and the nozzle is threaded into the body for easy removal and maintenance. This design can be supplied in steel, stainless steel, bronze, or Havg, an economical but highly serviceable modified epoxy resin containing silica fillers. In addition, these units can be made in any material required by the application. Standard materials are ductile iron body and diffuser with stainless steel nozzle. Flange ratings are 150 lb. and standard units have 150 psig internal design pressure.

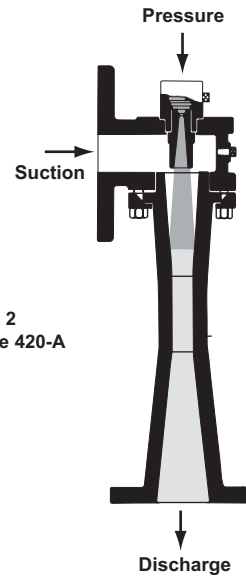
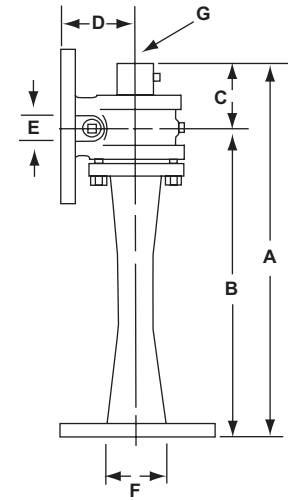

 Fig. 2
Type 420-A

 Fig. 3
Type 420
Jet Compressor

TABLE 1. SIZES AND DIMENSIONS - TYPE 420 COMPRESSORS

Size (Inches)	Unit Dimensions				Connections			Net Weight (Lbs.)
	A	B	C	D	E	F	G	
1	11 19/64	8 7/8	2 27/64	2 7/8	1	1	3/4	14
1 1/2	16 7/16	13 1/4	3 3/16	3 3/8	1 1/2	1 1/2	1	18
2	21 9/16	17 11/16	3 7/8	3 5/8	2	2	1 1/4	36
2 1/2	26 41/64	22 1/16	4 37/64	3 7/8	2 1/2	2 1/2	1 1/2	65
3	31 43/64	26 7/16	5 15/64	4 5/8	3	3	2	104
4	42 27/64	35 5/16	7 7/64	5 7/8	4	4	2 1/2	203
5	53 55/64	45 7/8	7 63/64	7 1/2	6	5	3	300
6	64 21/64	54 1/2	9 53/64	7 1/2	6	6	3	450

Note: Suction and discharge flanges are 150 lb. ANSI.



TYPE 425 JET COMPRESSORS

This compressor has all threaded connections and is equipped with a manually-controlled spindle. In this design, the high pressure gas is regulated by the spindle. When the handwheel is turned, the needle point of the spindle moves into or away from the inlet end of the pressure nozzle. This permits adjustment of the jet to obtain maximum efficiency.

Compressors with manually-controlled spindles are used when the unit operates at a steady load but where flexibility in nozzle orifice is desired to compensate for changes in operating conditions. When the compressor is first placed in service, the spindle is adjusted for existing conditions by means of the handwheel. Should conditions change (other gases be used) the spindle can be readjusted to compensate. The spindle cannot be used for tight shut-off. A valve in the pressure line should be provided for this purpose.

TABLE 2. SIZES AND DIMENSIONS - TYPE 425 COMPRESSORS

Size No. In Inches (Suction)	Connections (Inches)		Dimensions (Inches)		Weight (Lbs)
	Pressure Inlet	Disch.	Overall Length	Overall Width	
3/4	3/8	3/4	9 15/16	2 13/16	4
1	3/8	1	11 5/8	3 11/16	5
1 1/2	1/2	1 1/2	15 3/8	4 1/2	10
2	3/4	2	20	5 5/8	15
2 1/2	1	2 1/2	23 7/8	6 3/8	25
3	1 1/4	3	28 1/8	7 5/8	40

The Type 425 can be made in any material required. Standard materials include cast iron, bronze, and steel with stainless steel nozzle and spindle. Some units are carried in stock, consult factory.

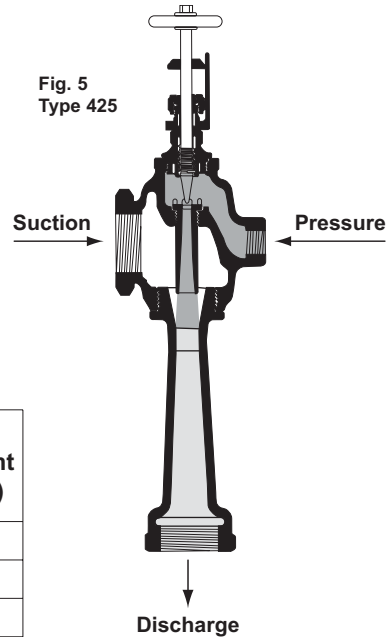
**Fig 4
Type 425
Jet Compressor**
TYPE 427 JET COMPRESSORS

The Type 427 Compressor is the flanged version of the Type 425 described above. As illustrated, all connections are flanged. Otherwise, it is the same as the Type 425 in construction. Standard material is steel body and diffuser with stainless steel nozzle and spindle, although the Type 427 can be made in any other materials, as required.

TABLE 3. SIZES AND DIMENSIONS - TYPE 427 COMPRESSORS

Size No. In Inches (Suction)	Connections (Inches)		Dimensions (Inches)		Weight (Lbs)
	Pressure Inlet	Disch.	Overall Length	Overall Width	
4	2	4	40 1/4	9	85
5	3	5	46 3/4	10 5/8	140
6	4	6	58 5/8	12 3/8	200
8	5	8	104 3/4	17	550
10	5	10	128 1/4	22	900
12	6	12	142	22 1/2	1050
14	8	14	161 1/2	24	1650
16	10	16	183 3/4	32	2100
18	10	18	195	35 1/4	2600

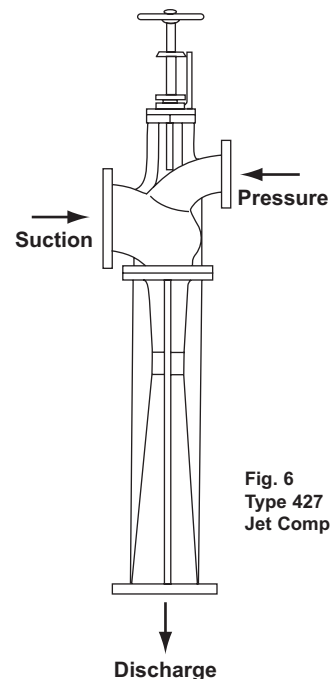
**Fig. 6
Type 427
Jet Compressor**

TYPE 426 JET COMPRESSORS

Type 426 Jet Compressors have automatically-controlled spindles. They are used when pressure, suction, or discharge conditions vary and it is necessary to control discharge pressure or flow. These units are made in 3 thru 24 inch sizes with flanged connections.

The spindle can be operated with a diaphragm, piston, or motor actuator using any standard instrument signal - electric or pneumatic. The control can be activated by temperature, pressure, flow or suction to motive gas ratio.

Type 426 Compressor spindles are designed to act as temporary valves and provide tight shut-off. For temperatures above 400°F, spindle and seat should be hard-faced to resist wear.

These compressors are made in materials to fit operating conditions or as specified by customer. Standard materials are steel body and diffuser with stainless steel nozzle and spindle. Standard flange ratings are 300 lb. but other ratings can be furnished, as required.

TABLE 4. SIZES AND DIMENSIONS - TYPE 426 COMPRESSORS

Size No. In Inches (Suction)	Connections (Inches)		Dimensions (Inches)		Weight (Lbs)
	Pressure Inlet	Disch.	Overall Length**	Overall Width**	
3	1 1/2	3	64 1/16	16	206
4	2	4	67 13/16	16	250
5	3	5	81 1/8	21 1/8	324
6	4	6	101	21 1/8	516
8	5	8	118 1/16	21 1/8	678
10	5	10	125 15/16	21 1/8	986
12	6	12	145 1/2	21 1/8	1176
14	8	14	166 5/16	21 1/8	1510
16	10	16	178 1/2	21 1/8	2350

**Includes diaphragm-type spindle controller.



Fig. 7
Type 426
Jet Compressor

TYPE 439 JET COMPRESSORS

The Type 439 Compressor is the threaded-connection version of the Type 426 Compressor described above. All connections are threaded, otherwise, this unit is the same as the Type 426. The Type 439 can be made in materials to fit conditions. Standard materials include cast iron, bronze, and steel, with stainless steel nozzle and spindle.

TABLE 5. SIZES AND DIMENSIONS - TYPE 439 COMPRESSORS

Size No. In Inches (Suction)	Connections (Inches)		Dimensions (Inches)		Weight (Lbs)
	Pressure Inlet	Disch.	Overall Length†	Overall Width†	
3/4	3/8	3/4	21 1/2	11	28
1	3/8	1	22 5/8	11	30
1 1/2	1/2	1 1/2	30 7/8	13 3/4	32
2	3/4	2	34 3/4	15 7/8	36
2 1/2	1	2 1/2	44 3/4	15 7/8	45
3	1 1/4	3	55	17 3/4	58

† Includes diaphragm-type spindle controller.

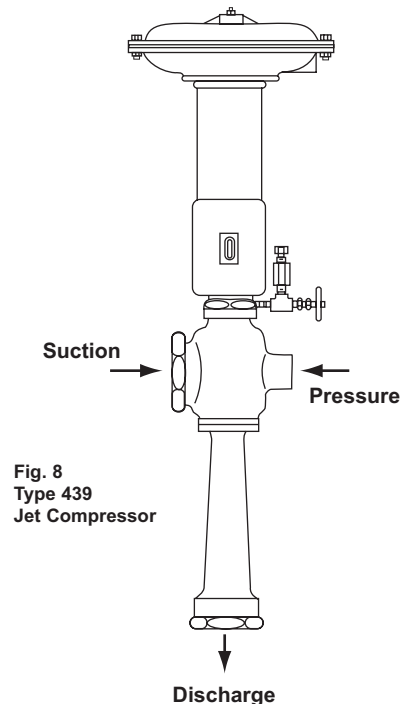

Fig. 8
Type 439
Jet Compressor

APPLICATIONS

Jet compressors are used to circulate steam, boost low-pressure steam, compress, and mix gases. The major applications are described, and several typical applications are illustrated. To help you evaluate jet compressors in terms of your specific application, request a copy of "Performance Data Supplement to Bulletin 4F."

RECIRCULATING

In accomplishing a "recirculating" function, a jet compressor takes steam which would otherwise be wasted and recirculates it through a heating device. It does this by utilizing higher-pressure steam to entrain the low-pressure steam and discharge at an intermediate pressure to the device - a tire vulcanizer, a paper mill Yankee Dryer (both illustrated), drying roll, or any type vessel where it is difficult to remove condensate as, for instance, a heat exchanger.

Process plants, where heating is accomplished by condensing steam, and condensate removal is a problem, use jet compressors instead of reducing valves. The lower-cost compressor increases the velocity of steam flow through a system and carries condensate with it. Without a compressor, condensate must be removed by the often impractical method of blowing down the system.

The jet compressor recirculates without loss of heat or energy. By using exhaust steam which might otherwise be wasted, the compressor improves heat transfer rates and increases the heating or drying capacity of the apparatus being used. Energy normally lost in a reducing valve is used to circulate the steam through a system. The jet compressor increases velocity of flow and thus "sweeps" condensate along with the steam.

Jet compressors used in recirculation of steam are usually automatically controlled because pressure for the device to be heated must be controlled. Control is about the same as that required for a reducing valve, namely pressure and temperature. Essentially, controls should provide for a variable throttling range and a reset feature. The jet compressor will desuperheat to some extent. However, where steam pressure and temperature are higher than the compressor can handle, additional desuperheating equipment should be used. Such equipment is described in Schutte & Koerting Bulletin 6D.

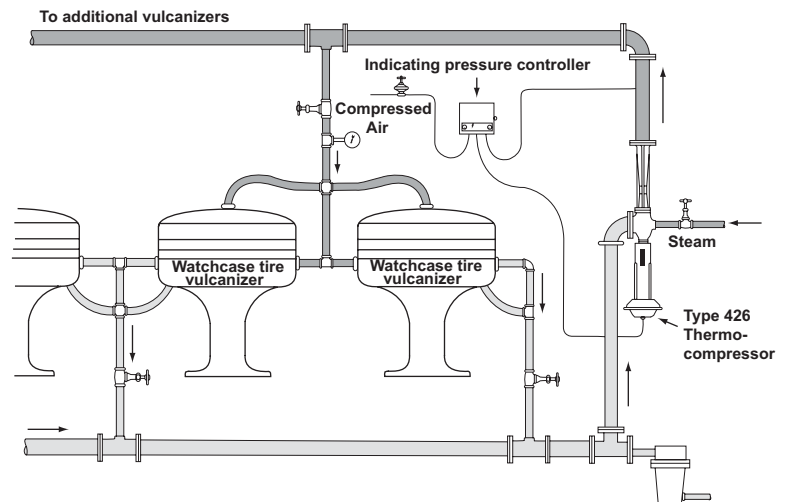

Fig. 9. Watchcase vulcanizers used in making rubber tires and tubes offer an excellent example of Type 426 Steam Jet Compressors engaged in recirculation. Here, a constant circulation of steam is necessary to avoid air and condensate pockets and resulting undercured spots in the product. The compressor discharges at a velocity sufficient to maintain proper recirculation of the steam and to accelerate removal of condensate which would otherwise lower the efficiency of the operation. Only enough live steam is required to make up for that which has been condensed.

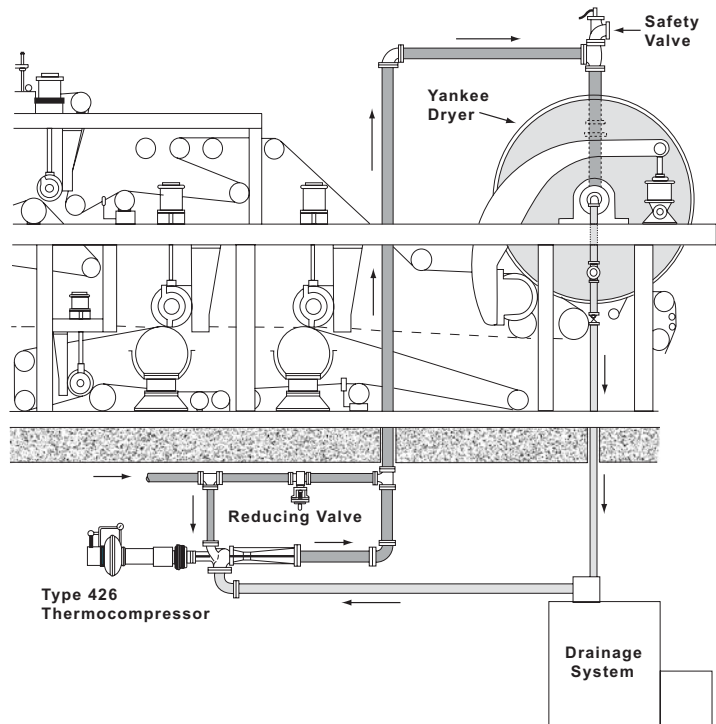

Fig. 10. In this application, Type 426 Steam Jet Compressors are used for recirculating in connection with a Yankee Dryer for paper. Regulation here must be precise to maintain proper steam temperature on the drying rolls used for tissue paper. Pressure difference between suction and discharge must be maintained at a level high enough to overcome the combination of the pressure drop within the roll, the centrifugal force of the condensate to be removed, and the pressure losses in the piping and condensate separator or flash tank. Automatic regulation is by means of an air-operated pressure controller and diaphragm or piston operator. This same system is also being used for banks of dryer rolls on newsprint and board machines.

REDUCING AND COMPRESSING

Jet compressors can be used to advantage in plants by compressing steam or reducing pressure.

For instance, a plant may have been built originally to provide steam at certain pressures. Over a time, conditions might change to an extent where available pressure no longer provide a sufficiently wide range. A Jet Compressor can correct the condition.

In cases where steam pressure is too high, the jet compressor can mix the high pressure steam with exhaust steam and produce the required discharge pressure.

In such operations, the cost of a jet compressor plus steam saving should be compared with the cost of a reducing valve.

Where steam pressure is too low, and high pressure steam is available for operating the unit; the compressor will mix the two and boost the low-pressure steam. Operating steam can be from plant condensate, steam from a low-pressure main, exhaust from a turbine, or other.

As a rule of thumb, if 1 lb. of low-pressure steam can be entrained using 6 lbs. of motive steam, a jet compressor will prove to be economical.

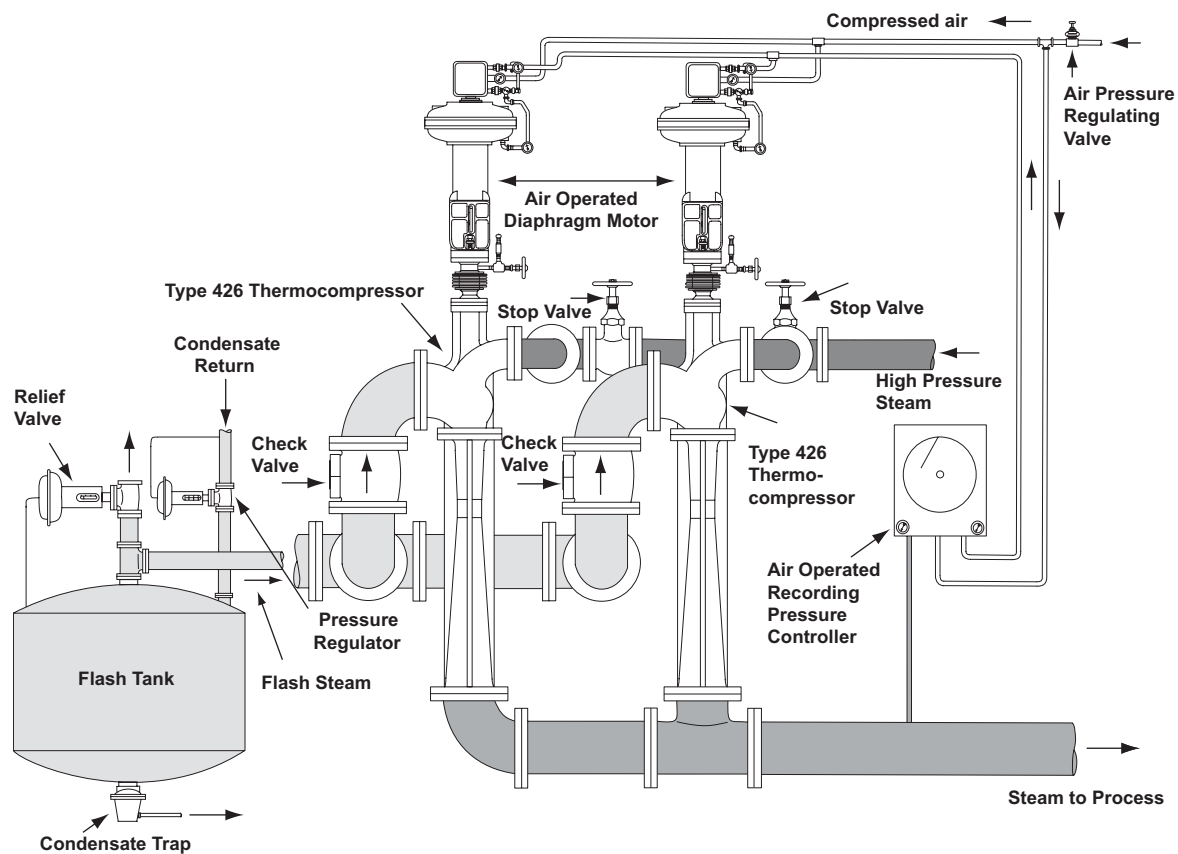

Fig. 11. Here, Type 426 Jet Compressors are used to boost the pressure of flash steam from a condensate receiver. Normally, this steam would be at atmospheric pressure. The two compressors use high pressure steam to entrain the flash steam and discharge at an intermediate pressure into a main which distributes the supply throughout a plant. An air operated pressure controller is affected by the pressure in the main and causes an increase or decrease in the pressure in the air line to the control mechanism on the compressor. A pressure relief valve acts as a guard against the building up of pressure in the receiver. The control system operates the two units in sequence and allows operation at a satisfactory entrainment ratio with varying capacities. The first one operates up to its full capacity before the second begins to operate. Upon load decrease, the second unit shuts down completely before the first unit begins to reduce.

GAS COMPRESSING

Jet Compressors make it possible to mix natural gas or L-P gases in desired proportions without the need for complicated apparatus. In many installations, jet compressors are used when the necessity arises for making a gas of proper heating value and density to substitute for another gas normally used. They will take care of peak load conditions or provide emergency supplies in case of breakdowns.

Using jet compressors, propane, butane, or natural gas can be mixed with air. Natural and manufactured gases can be mixed in proportion to obtain desired heating value.

In gas mixing applications, automatic spindle control is not important since these units are designed for constant mixing ratio. Once adjusted, the compressor will perform consistently. To obtain a system with enough flexibility to match load variations, multiple units are usually used in parallel.

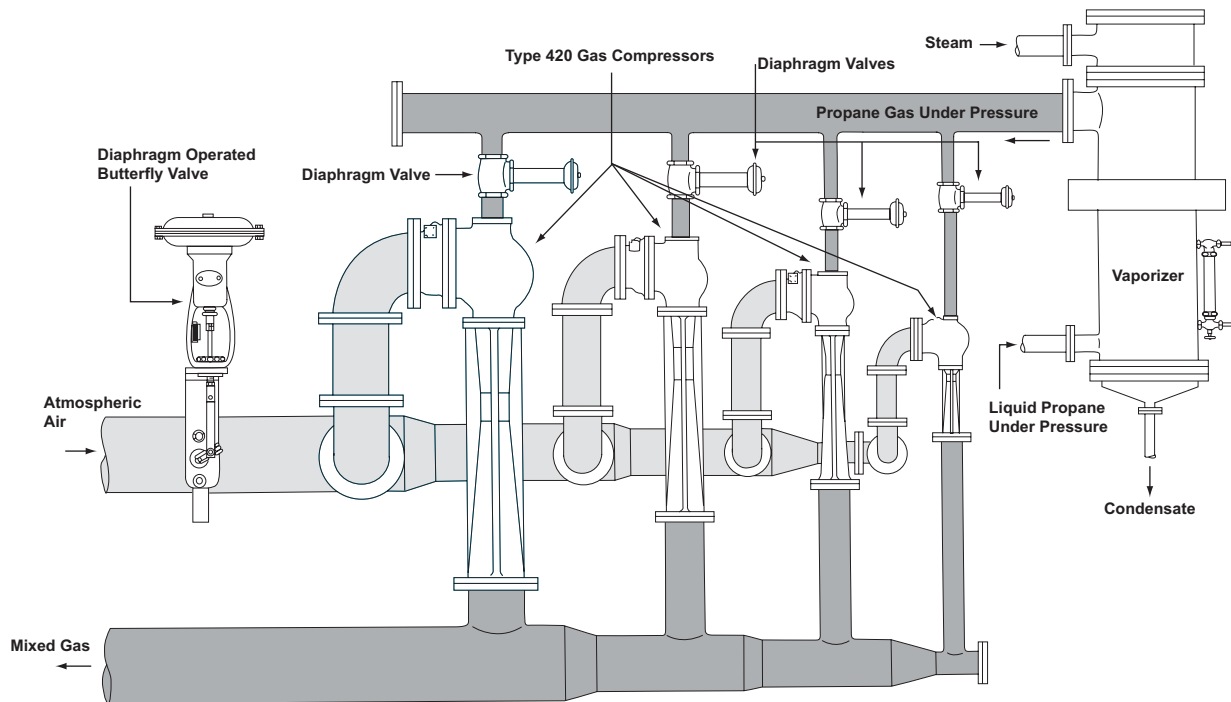

Fig. 13. The compressors in this application do not have regulating spindles, but the set of units is sized so that 15 variations of capacity are available. Each unit will handle double the capacity of the next smaller size, and each gas compressor is operated wide open or is shut off by means of a plug valve. A check valve should be installed on the suction side of each compressor to close automatically to prevent backflow of gas to intake manifold when a given compressor is shut off. The air intakes are connected in manifold. Automatic regulation can be obtained by controlling the gas inlet valves in "on" or "off" position, and by regulating a butterfly valve as shown. This permits control by means of a continuous calorimeter.

010606

