

an **ASME** publication

The Society shall not be responsible for statements or opinions advanced in papers or in discussion at meetings of the Society or of its Divisions or Sections, or printed in its publications.

Discussion is printed only if the paper is published in an ASME journal or Proceedings.

Released for general publication upon presentation

Improvements in Steam Desuperheater Performance

By: L. S. HARRIS
Manager, Research and Development Department,
Schutte and Koerting
Bensalem, PA

Development work performed during the past ten years in the field of direct-contact steam desuperheaters has produced several new types of pipeline desuperheaters having improved range and performance. The various basic types of direct-contact steam desuperheaters used in the various processing industries and in power plants are outlined and discussed. Experimental investigations leading to the design and development of a new type of steam ejector atomizing desuperheater and an annular-venturi-orifice desuperheater having 50-1 operating ranges at temperatures down to 10 deg F above saturation are discussed and presented in chart form

Improvements in Steam Desuperheater Performance

The controlled cooling of steam temperatures above saturation after it leaves the boiler is achieved by the steam desuperheater. They are used in numerous chemical and manufacturing processes where controlled steam temperatures are required. They are also used for the protection of turbines, valves, and pipeline equipment; and they are used to protect against high temperatures resulting from load changes in the plant steam system, for reducing size and cost of surface condensers, and for increasing the mass flow of the steam at a lower temperature level.

Desuperheater Types

The various basic types of direct-contact desuperheaters can be classified as being either venturi-orifice type, spray-type, or surface-type units. A comparison of the general characteristics and differences of various type units are shown on Table 1.¹² Venturi-orifice units are among the highest cost units and have the general advantageous characteristic of not requiring water or steam pressure higher than the steam pipeline pressure. Consequently, they can be used in high-pressure applications at steam pressures at or near the boiler pressure. Venturi-orifice units achieve their injection, atomization, and distribution of water into the steam by the high velocity and corresponding lower pressure phenomenon existing in the reduced area throat section. Variable venturi-orifice desuperheaters have minimum flow characteristics of 2 percent, thereby permitting operation over a 50-1 variation or turn down in pipeline steam flow. However, such units have moving mechanical parts in the main steam stream. In applications requiring the use of reducing valves, the venturi desuperheater can be intergrated into the throat section of the valve, thereby forming a combination reducing valve and variable-orifice desuperheater. Such arrangements have been in use in this country since the early 1930's. The annular-venturi-orifice (A-V-O) desuperheater, a recent development resulting from several years of research of research and development achieves the 50-1 operating range with low pressure drop and without the use of moving mechanical parts in the pipeline. Prior to its development, venturi-orifice desuperheaters either had high pressure drop or had to be of the variable-orifice type in order to achieve low pressure-drop characteristics.

The spray units, for the most part, are structurally simpler and have the advantageous characteristics of being lower in cost and having very low pipeline pressure drop. However, they require the use of steam and/or water pressures considerably higher than the main steam pipeline pressure. The simple water-spray nozzle units achieve their atomization, injection, and distribution into the main stream by means of much higher water pressure, which may be in the range of 200-300 psig above the steam pipeline. Although they are the simplest and lowest cost units, they have the major disadvantage of a very limited operating range. For flow variation, the nozzle pressure difference between the maximum and minimum flows has to be the square of the flow variation. Steam atomizing spray desuperheaters are considerably lower in cost than the venturi-orifice units but higher in cost than the water-spray units and have a higher operating range. They achieve their injection, atomization and distribution by the use of a small quantity of atomizing steam at high velocity. The high velocity is achieved by the use of higher steam pressure. These units also require the water to be supplied at a pressure considerably higher than the main steam pipeline pressure. The steam ejector-atomizing unit, a recent development, is similar to the steam-atomizing units but uses the ejector principle. Consequently, it does not require water pressure higher than the main steam pipeline pressure. The recycle steam ejector-atomizing unit, another recent development, achieves 50-1 and higher operating flow range performance previously only attainable in venturi-orifice units.

The surface absorption type is also among the highest cost units. It has the major advantage over the spray and venturi-orifice units of being completely free of the possibility of clogging of small water or

¹ C.G. Blatchley, "Make Sure You Buy The Right Desuperheater," Power, February, 1962.

² "Steam Desuperheater," Schutte & Koerting Company, Bulletin 6D, February 1963.

steam injection holes. The water is let into the unit by a pipeline at water pressures only slightly higher than the main steam pipeline pressure. It achieves the desuperheating action by having the entire pipeline steam flow come in contact or pass through a packed tower arrangement having a very large amount of wetted surface, obtained with the use of raschig or pall rings.

Table 1 Comparison of Characteristics of Various Types Desuperheaters

Type	Operating Range	Design Configuration Type	Moving Mechanical Parts	Pipe Line Water Drainage Required (Uses Excess Water)	Pipe Line Pressure Drop	Cooling Water Pressure Equipment (Relative to Steam Pipe Pressure)	Atomizing Steam Pressure Requirement	Relative Cost
VENTURI-ORIFICE								
Pipe Line Flow Nozzle	5-1	Pipe Line	No	No	High	Same	None	Moderate
Downward Flow Nozzle	10-1	Chamber	No	Yes	High	Same	None	Moderate
Double Venturi	7-1	Pipe Line	No	No	High	Same	None	Moderate
Variable Orifice	50-1	Pipe Line	Yes	No	Low	Same	None	High
Reducing Valve	50-1	Reducing Valve	No	No	High	Same	None	Very high
Annular Venturi	50-1	Pipe Line	No	No	Low	Same	None	High
SPRAY TYPE								
Water Spray Nozzle	2-1	Pipe Line	No	No	Nil	Much higher	None	Very high
Water Spray Nozzle in Chamber	10-1	Chamber	No	Yes	Low	Much higher	None	High
Steam Atomizing	10-1	Pipe Line	No	No	Nil	Higher	Higher	Low
Steam Ejector	7-1	Pipe Line	No	No	Nil	Same	Higher	Low
Recycle Steam Ejector	50-1	Pipe Line	No	No	Nil	Same	Higher	Low
Atomizing								
SURFACE TYPE								
Surface Absorption	50-1	Chamber	No	Yes	High	Higher	None	High

As shown in Table 1, no one unit is advantageous for all types of conditions and applications. At one extreme, the water-spray nozzle unit is by far the lowest cost and the simplest, however it is restricted to low flow-range variations and requires external water pressure higher than the pipeline. At the other extreme, the combined reducing valve and variable venturi-orifice desuperheater has a 50-1 flow range, is mechanically more complex, and very much higher in cost. Similar intermediate application comparisons between the aforementioned extremities can be made for the various other units.

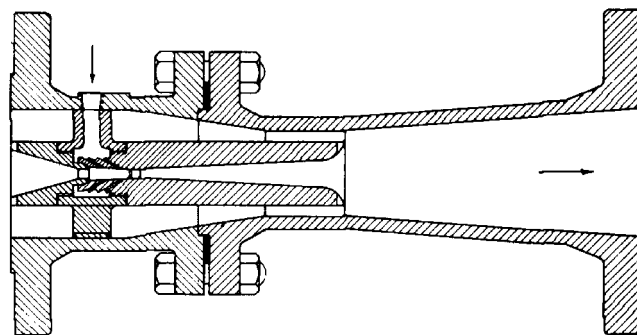

Fig. 1 Venturi desuperheater

In the past ten to twenty years many technical improvements and advance have been made in direct-contact desuperheaters. These have consisted of the development of new design and operating concepts, resulting in more compact, lower weight, and lower cost pipeline units that can be completely supported by the steam pipe connections. This is in comparison to older types which consisted of chambers considerably larger in size than the pipeline and heavier in weight requiring individual mounts and supports. The newer designs and developments have greatly improved ranges of performance, operating flow ranges as high as 200-1, as compared to the 10-1 flow ranges of the older units. These

improvements have been evolved as a result of several years of research and development. This work disclosed that direct-contact desuperheating involves considerably more than simply spraying atomized water into a pipeline or into the throat of an orifice. Direct-contact desuperheating is a combination of heat-transfer and mass-transfer phenomena that is not instantaneous in action but requires time. As such it is affected and influenced by the amount of surface, velocity, viscosity, density, temperatures, pressures, and enthalpy of both the steam and cooling water mediums.

Experimental Work

As a result of the demands by industry for higher performance, lower cost pipeline desuperheaters, the desuperheating phenomena of a venturi desuperheater as shown in Fig. 1 was experimentally investigated in a horizontally straight 3-in. pipeline. The test set up was fitted with sight glasses at 5 and 30 ft. from the desuperheater outlet, with thermocouples every 5 ft. along the pipe and with several different types of temperature control sensing devices. The investigations were conducted at inlet and outlet temperatures from a few degrees above saturation up to 600°F. superheat and pressures in the range of 10 to 100 psig. The typical performance characteristics obtained for 200 and 500°F inlet superheat versus desuperheater flow range for a venturi desuperheater are shown in Fig. 2. The performance curves shown were defined by the outlet temperature existing at 30 ft. from the desuperheater at which water could be seen to begin to appear in the bottom of the pipe at the sight glass at 30 ft. from the desuperheater. Because of the extreme difficulties to control the system conditions very near saturation, the lowest desuperheater discharge temperature for practical reasons was limited to 5°F above saturation.

By permitting excess water to be removed from the steam pipeline with a trap at a point approximately 30 ft. from the desuperheater, the obtainable approach temperatures at the lower pipeline velocities in the range of 10 to 40 percent desuperheater flow capacity could be reduced to the range of 10°F above saturation. The approach temperature characteristics for various quantities of excess desuperheater cooling water was experimentally investigated at 10 percent flow for the 3 in. horizontally mounted venturi desuperheater. The results of these

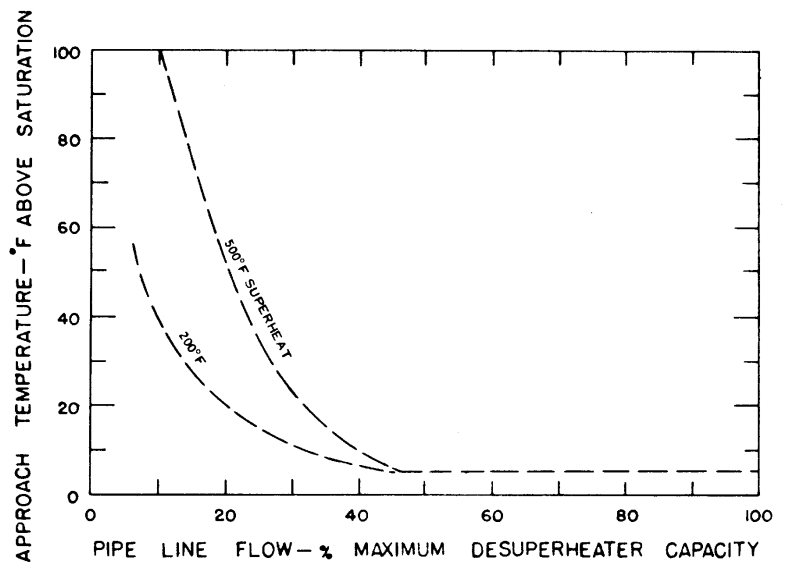

Fig. 2 Typical performance curves for a venturi desuperheater with no excess cooling water

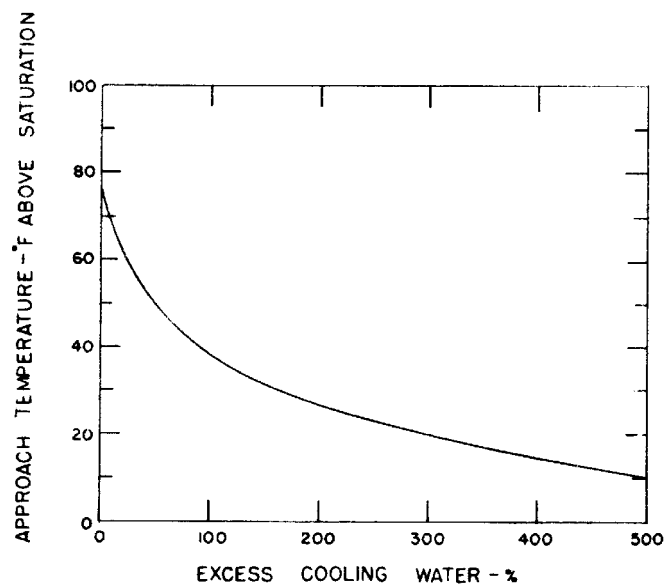

Fig. 3 Performance of a venturi desuperheater at 10 percent flow capacity with excess cooling water

tests performed at 90 psig and 700°F inlet conditions are shown in Fig. 3. As illustrated, the outlet temperature 30 ft. from the desuperheater was reduced to 10°F at 10 percent flow but 500 percent excess water was required. The 500 percent excess water at 10 percent pipeline steam flow is approximately 60 percent of the water required at 100 percent steam-flow conditions. Consequently, if a steam pipeline were equipped with traps and automatic controls, the desuperheating system may outwardly appear to be functioning satisfactorily. The water control valve, the controller thermal sensing device, and the controller as a system still respond to changes in temperature. However, the excess water flowing in the steam pipe is generally considered to be very undesirable.

Similar tests were conducted with the unit and pipeline mounted in a vertical upward direction. The performance of the unit without the use of excess cooling water was observed to be better than that shown in Fig. 2 for the horizontal position. The limit of satisfactory operation for the vertical mounting with the use of automatic controls and excess desuperheating cooling water was found at 10°F to be 10 percent flow and at 20°F to be 5 percent flow.

The loss in desuperheating performance at the lower flows in the venturi-orifice desuperheater is obviously caused by the decrease in steam velocity available for atomizing the water. As shown in Table 1 the venturi-orifice desuperheaters do not use excess or additional water or steam pressure for atomization, but obtain atomization by the velocity of the main steam flow.

Similar tests were conducted on a steam-atomizing desuperheater mounted in a horizontal pipeline. General performance characteristics were similar but somewhat improved over those shown in Fig. 2. Desuperheater performance down to 10 and 20°F above saturation at flows lower than 10 percent could be obtained, but only at the expense of the use of considerable excess water.

During the various experimental tests with the pipeline desuperheaters mounted horizontally, visual observation in the sight glass at 5 ft. from the desuperheater revealed the pipeline walls to be wet all over, considerable entrained water droplets, and some water lying in the bottom of the pipe. In addition, the thermocouple at 5 ft. from the desuperheater indicated saturation temperatures even with desuperheated temperatures as high as 100°F superheat at 30 ft. from the desuperheater. A typical set of observed temperature gradients along the pipeline for the venturi-orifice unit at various pipeline velocities for conditions producing 10°F approach temperature at 25 ft. from the desuperheater are shown in Fig. 4. The data shown are for a pipeline pressure of 25 psig and an inlet steam temperature in range of 500 - 575°F. The indication of saturation temperature at 5 and 10 ft. is

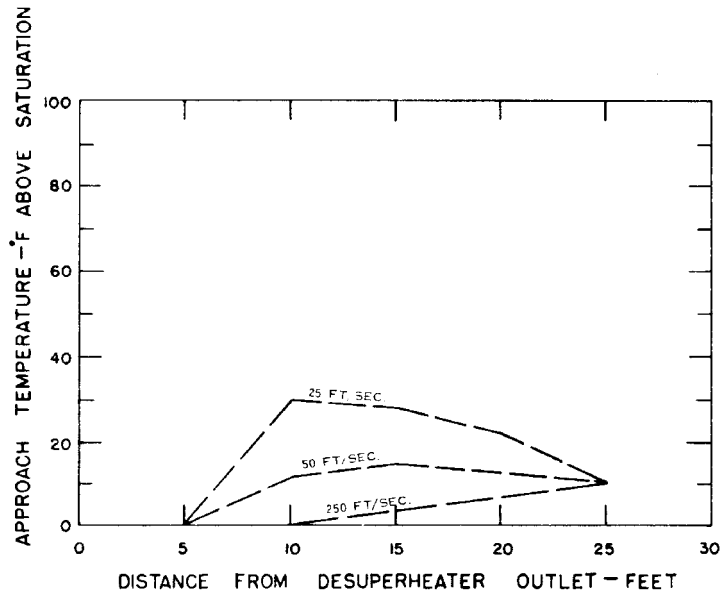

Fig. 4 Venturi desuperheater pipeline temperature gradients at various pipeline velocities

because of the thermocouples being bombarded by the entrained water droplets. The peak points existing at 10 and 15 ft. for the 25 and 50 fps pipeline velocities respectively are indications of the time required to achieve desuperheating. The decrease temperature after the peak points, which become especially pronounced at the lower velocities, is believed to be principally due to the cooling effect of the excess quantities of water flowing along the bottom of the pipe as previously explained and illustrated in

Fig. 3. At the 25 fps velocity the peak point at 10 ft. indicates 0.4 sec is required for desuperheating, and at 50 fps, 0.3 sec.

At 250 fps the steam reaches the 25 ft. point in 0.1 sec. As indicated by the slope of the 250 fps pipeline velocity curve the desuperheating action is not complete. Assuming a log-log mathematical relationship between velocity and time for completing desuperheating, at a velocity of 250 fps, 0.15 sec. or 37-1/2 ft. is required.

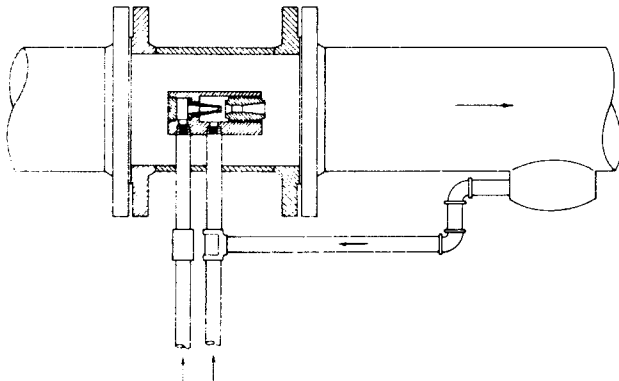

Fig. 5 Recycle steam ejector-atomizing desuperheater

Recycle Desuperheater Development

The abovementioned tests disclose that improvements in desuperheater performance for both venturi-orifice and steam atomizing units to the general vicinity of 10°F above saturation and flows as low as 2 percent of full rated capacity were attainable. However, a combination of additional water, wetted surface, and/or contact time would be required. Recognizing that continuous drainage of excess water from the pipeline is considered undesirable, a recycle steam ejector-atomizing desuperheater arrangement was developed. The arrangement permits injection and recycling of quantities of water into the steam stream which are considerably

greater than the theoretical amount supplied to the inlet of the desuperheater. This is accomplished by the use of the steam ejector-atomizing desuperheater shown in Fig. 5,³ which collects the excess water in the pipe by the sucking action of the steam ejector, and re-injects it into the steam stream. Only the theoretical amount of desuperheating water goes beyond the pipeline well located approximately 3 to 6 ft. from the desuperheater.

Due to the characteristics of approach temperature versus excess water, similar to that shown in Fig. 3; when the quantity of excess water circulated at the low flow decreases, the outlet desuperheater temperature increases. This action causes the automatic control to let water into the system. Orifices in the recycle and inlet cooling water lines and sucking characteristics of the unit prevent the inlet water from bypassing the steam ejector-atomizing unit. With an atomizing steam-to-pipeline pressure ratio of 2; 10°F approach temperature was attainable over a flow range from 100 percent down to the amount of steam used in the atomizer. The atomizing steam quantity varies depending upon the amount of desuperheating required and is in the general range of 0.5 to 2 percent of the main steam flow. The effect of decreased atomizing velocity on the recycle-desuperheater performance is shown by the performance of the unit at the atomizing steam pressure ratios of 2 and 1.5 at inlet pipeline conditions of 90 psig and 750°F, Fig. 6.

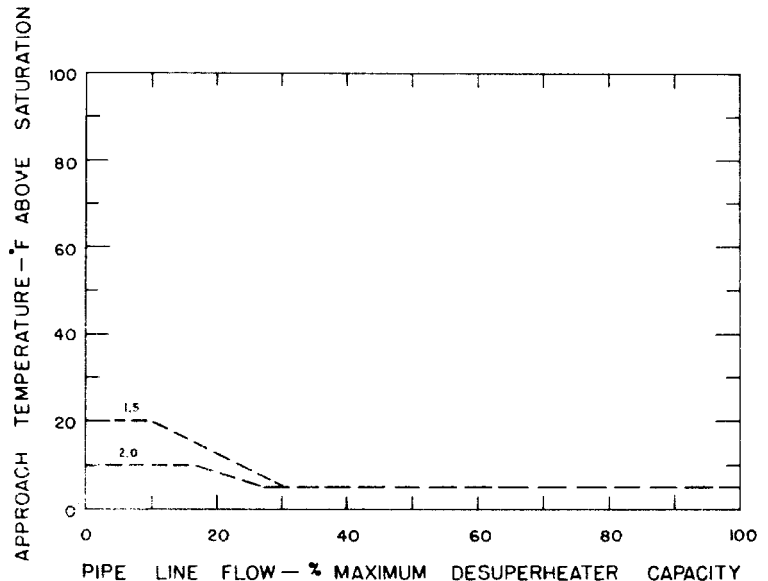

Fig. 6 Performance characteristics of recycle steam ejector-atomizing desuperheater at atomizing steam pressure ratios of 2 and 1.5

³ U.S. Patent No. 3,034,771, May 15, 1962; Desuperheater, L.S. Harris.

Steam Ejector-Atomizing Desuperheater

The performance of the same steam ejector-atomizing desuperheater in the horizontal position without the recycle arrangement is shown in Fig. 7. The performance shown was with an atomizing steam pressure ratio of 2, with inlet pipeline conditions of 90 psig and 750°F, and with water existing in the bottom of the pipe at 30 ft. from the desuperheater, but not flowing beyond the 30 ft. point. The major improvement in performance and the decided effect of the recycle phenomenon is clearly shown by comparing the performance shown in Figs. 6 and 7.

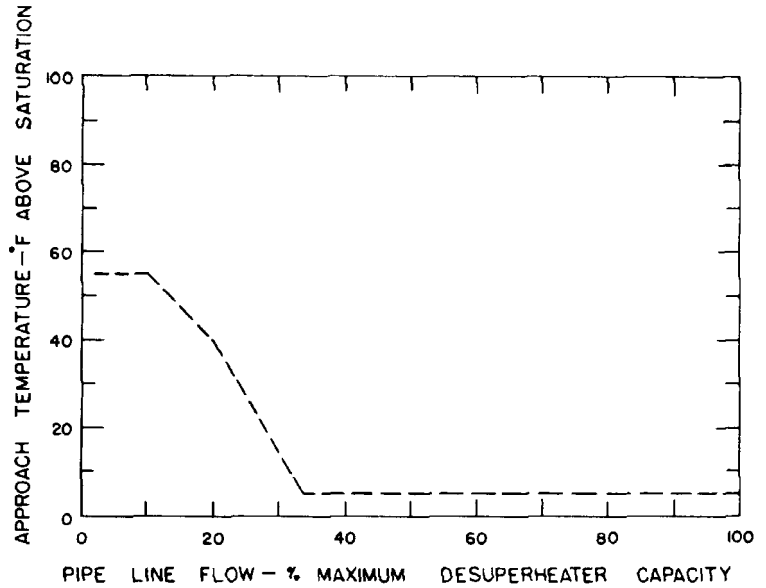

Fig. 7 Performance characteristics of steam ejector-atomizing desuperheater without recycle well, with atomizing steam pressure ratio of 2

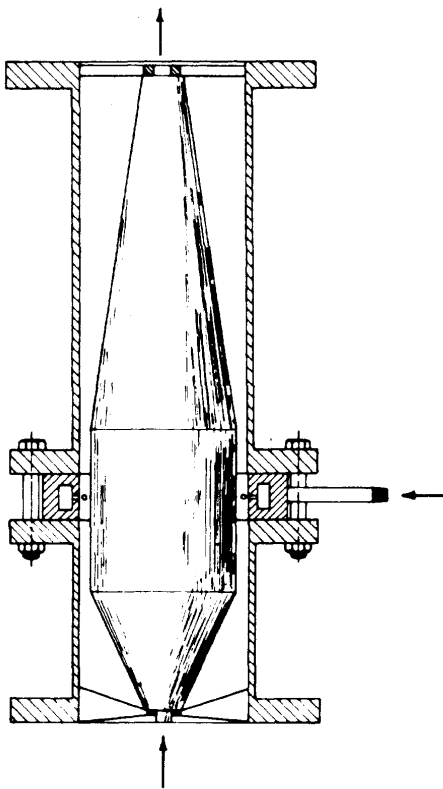

Fig. 8 Annular venturi-orifice desuperheater

Annular Venturi-Orifice Desuperheater

Achieving improved performance to 10°F above saturation at flow variations down to 1/50 of the full-rated capacity in a fixed venturi-orifice desuperheater was accomplished by increasing the amount of surface exposed to the main steam flow at lower velocities. It was achieved with an annular-venturi design and with the use of an upward flow arrangement, as illustrated in Fig. 8.⁴ This annular-venturi design arrangement with the water introduced at the outer periphery, produces a major increase in the area and surface over which the water is spread out at the point of first injection. In the annular venturi, the area over which the water is spread can be several times greater than in the conventional venturi and many more times greater than a venturi unit having its water injection in the center. The upward direction of the flow causes atomized water which becomes disentrained from the stream, to fall backwards due to gravity, down into the high velocity throat section where it becomes reentrained. This recycle action causes a greater quantity of water and surface to be in contact with the steam than from straight-through flow existing in a horizontal venturi-orifice arrangement. At the lower velocities where the main stream velocity is unable to provide sufficient atomization, the injected water falls downward into an extension of the high velocity throat section. The high

⁴ Patent Pending.

velocity section below the point of injection provides both surface and time necessary to achieve the 10°F approach temperature performance at flows down to 2 percent. Because of the greater surface over which the water is injected and the recycle feature, it was found experimentally that the venturi-throat areas could be considerably larger than the conventional venturi design, thereby greatly reducing the pressure drop across the unit.